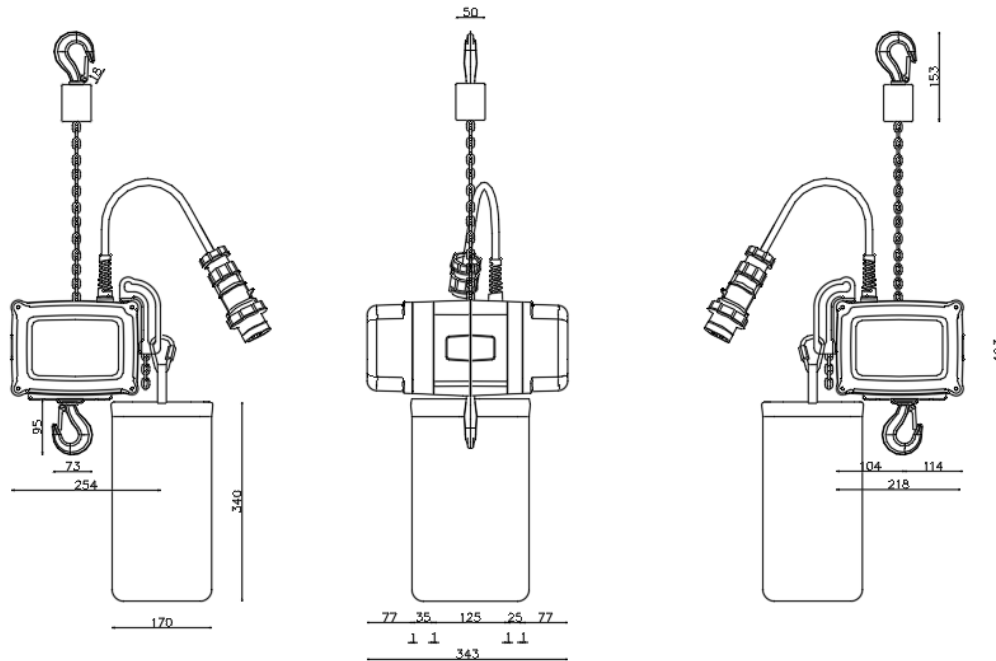

EX3
RISE

EXE RISE Chain Hoist Data Sheet

D8+ 250kg DC / LVC
3PH - 4 m/min - 2m - 1 Fall**DRAWING**

Measurements in [mm]

SPECIFIC FEATURES**DIRECT CONTROL**

Model	EXE RISE Chain Hoist D8+ 250 kg DC/LVC
Working Load Limit (WLL)	250 kg
Frequency	50 Hz
Lifting Speed	4 m/min ± 1%
Motor Power	0.5 kW
Power Supply Δ/Y	230/400 VAC - 3 - 50 Hz
Current	Δ 2.94 A - Y 1.70 A
Revolutions Per Minute	1400
Falls of Chain	1
Δ Power Supply Connector (*)	CEE 16A 9h 230VAC - 3PH + G plug
Y Power Supply Connector	CEE 16A 6h 400VAC - 3PH + G plug
Optional Limit Switch (*)	2 position
Brake Size	06
DC Brake Operating Voltage	103 VDC
DC Brake Rated Torque	4 Nm
DC Brake Nominal air gap	0.2 mm

(*) Only on request

LOW VOLTAGE CONTROL

Control Supply	24 VAC
Control Supply Connector	CEE 16A 4h 24VAC - 3PH + G socket
Standard Limit Switch	2 position

ACCESSORIES

CHAIN BAG	Bag size and meters of chain		
	S	M	L
Chain length	Max 25 m	Max 45 m	Max 65 m
Dimensions	17x20x34 cm	17x20x42 cm	17x27x58 cm
Self-weight	~ 1 kg	~ 1 kg	~ 1 kg

RAIN COVER	Size M for Standard or Self Climbing suspension		
FLIGHT CASE	2 hoist - dimensions 74x57x57 cm		
ENCODER	Absolute/Incremental (on other body)	HOUR COUNTER	On request
LOAD CELL	LC-NLP configuration		
LATCH LOCK HOOK	Size S		
SPECIAL NOTE	Maximum chain length	≤ 65 m	

Caution: The technical data and the drawing in this document may be subject to variations due to design changes. Please contact our office for the last revision.

GENERAL FEATURES

Self-weight	21.5kg (DC) / 23kg (LVC)
Type of Control	Direct or Low Voltage
Fem Class	2m
Duty Factor	40%
Start per Hour	240
Bearing Time/10 years	6300 h
Number of Brakes	2
Type of Chain	DIN EN 818-7 type DAT (Zinc galvanized steel 80 grade)
Size of Chain	5x15 mm
Safety Factor	8:1
Chain Self-Weight	0.54 kg/m
Hoist Body	Aluminium casing with matt black finish
IP Rate	55

Insulation Class (Temperature Class)	F in according to CEI 15-26
Load Wheel	5 pockets
Noise Level	67.5 db @full load
Connection Cable Length	(75 ± 5) cm
Body/Chain Hook	Swivel
Type of suspension	Standard or Self Climbing
Clutch	Force-Limiter
Plug and Socket	Black coulor
Handles	Work in either Orientation

Exe Rise Chain Hoist is CE marked in accordance to Machinery Directive 2006/42/EC and comply with the requirements of the new German Quality Standard SQP2:2018

info@exetechnology.com
www.exetechnology.com