



CONTROL SYSTEMS



12 Channel Rack Mount



6 Channel Rack Mount



12 Channel Wall Mount



6 Channel Wall Mount



12 Channel Wall Mount
Hardwired



6 Channel Wall Mount
Hardwired



3 Channel FILM

GenVI

Advanced Dimming and Power Switching System

User Manual

LSC Control Systems ©
+61 3 9702 8000
info@lsccontrol.com.au
www.lsccontrol.com.au



V4.04
May 2024

Disclaimer

LSC Control Systems Pty Ltd has a corporate policy of continuous improvement, covering areas such as product design and documentation. To achieve this goal, we undertake to release software updates for all products on a regular basis. In light of this policy, some detail contained in this manual may not match the exact operation of your product. Information contained in this manual is subject to change without notice.

In any event, LSC Control Systems Pty Ltd cannot be held liable for any direct, indirect, special, incidental, or consequential damages or loss whatsoever (including, without limitation, damages for loss of profits, business interruption, or other pecuniary loss) arising out of the use or the inability to use this product for its intended purpose as expressed by the manufacturer and in conjunction with this manual.

Servicing of this product is recommended to be carried out by LSC Control Systems Pty Ltd or its authorised service agents. No liability will be accepted whatsoever for any loss or damage caused by service, maintenance or repair by unauthorised personnel. In addition, servicing by unauthorised personnel may void your warranty.

LSC Control Systems' products must only be used for the purpose for which they were intended.

Whilst every care is taken in the preparation of this manual, LSC Control Systems takes no responsibility for any errors or omissions.

Copyright Notices

GEN VI dimmers are developed by LSC Control Systems Pty. Ltd.

“LSC Control Systems” is a registered trademark.

lsccontrol.com.au is owned and operated by LSC Control Systems Pty Ltd.

All Trademarks referred to in this manual are the registered names of their respective owners.

The operating software of the GEN VI and the contents of this manual are copyright of LSC Control Systems Pty Ltd © 2016.

All rights reserved.

Contact Details

LSC Control Systems Pty Ltd

ABN 21 090 801 675

65-67 Discovery Road
Dandenong South, Victoria 3175 Australia
Tel: +61 3 9702 8000

email: info@lsccontrol.com.au

web: www.lsccontrol.com.au

Contents

1	Introduction.....	6
1.1	About this Manual.....	6
1.1.1	Conventions Used in this Manual	6
1.2	Overview	6
1.2.1	Features	6
1.2.2	GEN·VI Control Philosophy	7
2	Quick Start Guide	8
2.1	DMX Address	8
2.2	Channel Modes	8
2.2.1	Dimmer or TruPower (Switch).....	8
2.2.2	Auto Power.....	9
3	Models	10
3.1	Front Panels	10
3.1.1	Rackmount GEN·VI	10
3.1.2	Wallmount GEN·VI	10
3.2	Output Connectors	11
4	Installation	12
4.1	Safety	12
4.2	Unpacking	12
4.3	Installation	12
4.3.1	Rackmount GEN·VI	12
4.3.2	Wall-mount GEN·VI	12
4.3.3	Patch Bay Installation	14
4.4	Connections	15
4.4.1	Input Power Supply	15
4.4.2	Wallmount GEN·VI Power Input Options	15
4.4.3	DMX512 Connections.....	15
5	Configuration and Operation	16
5.1	Overview	16
5.2	Help Screens.....	16
5.3	Home Pages.....	16
5.3.1	DMX Address Home Page.....	16
5.3.2	DMX Address	17
5.3.3	Dimmer Output Home Page	17
5.3.4	Status	18
5.3.5	Owner.....	18
5.4	Dimmer Status.....	19

5.5	Riggers Control.....	20
5.5.1	Chaser.....	20
5.6	Config Menu	21
5.7	Dimmer or Trupower (Switch).....	21
5.8	DMX Menu	22
5.8.1	Patch	23
5.8.2	16 Bit DMX Control.....	24
5.8.3	DMX Loss Memory	24
5.8.4	Auto Power Enable and Hold Time	27
5.8.5	Auto Power Mode.....	28
5.8.6	View Input.....	29
5.9	Set DMX Term.....	29
5.10	Channels Menu	29
5.10.1	Min Level.....	31
5.10.2	Max Level.....	31
5.10.3	Curve.....	31
5.10.4	Source (DMX or Auto Power)	33
5.11	Colour Theme Menu.....	33
5.12	System Menu	33
5.12.1	Code (Software) Upgrade.....	34
5.12.2	Reset.....	34
5.12.3	Fan Control.....	35
5.12.4	Import Export.....	35
5.13	Lock / Unlock.....	35
6	Alarms and Troubleshooting	37
6.1	Maintenance.....	37
6.2	Alarms	37
6.3	Trouble Shooting	38
6.3.1	Rigger Test.....	38
6.3.2	DMX Control.....	38
7	HOUSTON X.....	39
8	DMX Explained	40
8.1	Overview	40
8.2	Typical DMX Installations	40
9	RDM	41
9.1	Overview	41
9.2	GEN-VI RDM.....	41
10	PTFD Explained	42
10.1	Overview	42

10.2	What is PTFD?	42
10.3	Opto-isolated Problems	42
10.4	Hard Firing.....	42
10.5	The Proof.....	43
11	Specifications and Output Options	44
11.1	Rackmount GEN·VI	44
11.2	Wallmount Gen VI	45
11.3	Socapex Pinouts.....	46
11.4	Harting/Wieland Pinouts	47
12	Feature History.....	47
13	Compliance Statements	50

1 Introduction

1.1 About this Manual

This manual describes the installation, configuration and operation of the GEN·VI range of advanced dimmer/power systems manufactured by LSC Control Systems:

- GEN·VI Rackmount
- GEN·VI Wallmount
- GEN VI Film

There are four different colour themes that you can select on the GEN·VI touch screen. The screen images in this manual use the default “Gothic” colour theme and a 12-channel model.

1.1.1 Conventions Used in this Manual

Throughout this manual, certain conventions have been used to make the meaning clearer.

- A word in **Bold** text represents a button on the touch screen
- Emphasis is indicated by underlining
- *Notes or Hints are displayed in italic font*

1.2 Overview

The GEN·VI dimmers can be controlled by any DMX512 lighting controller. Dimmer configuration, patching and local control is achieved via a backlit colour touch screen on the front panel. A lock code can be used to prevent unauthorised tampering. Most control functions, configuration options and front panel operations can also be remotely controlled using the RDM (Remote Device Management) protocol. System configuration, monitoring and logging is also possible via LSC’s HOUSTON X software.

1.2.1 Features

- DMX512 (1990), DMX512-A (E1-11) and RDM (E1-20) compliant control.
- If DMX is lost, the GEN·VI can either hold the last values or fade to a “DMX Loss memory” after a programmable delay.
- RCBO (Residual Current Breaker with Overcurrent) per channel. This is a combined overload circuit breaker with earth leakage (RCD/GFI) protection and Neutral Disconnect function for each circuit.
- One of the most catastrophic faults that can occur on any power system is a “dropped” neutral. If a neutral is not present at power-up or drops out during a show, the GEN VI will shut down the outputs within 50ms, providing protection to your connected equipment.
- Individual dimmer channel settings for:
 - DMX address patching.
 - Minimum and maximum output levels.
 - Choice of three fade curves (linear, s, or custom) or LSC TruPower (switched) power output.
- LSC TruPower (switched power) provides direct power output by utilising relays guaranteeing there are absolutely no electronics in the circuit to interfere with connected loads. Ideal for discharge lamps and LEDs.
- LSC’s proprietary Current Control Technology © (CCT) protects all RCBO’s from nuisance tripping due to cold lamp inrush currents.
- GEN·VI Rackmount has either 10, 16 or 25 amps per channel models with a choice of rear output connectors.
- GEN·VI Wallmount has either 10 or 25 amps per channel models with a choice of front output connectors or internal output terminals.
- Settable constant fan speed or fully automatic.
- 16 bit internal architecture which gives smooth fades. Essential when dimming LEDs.
- 16 bit DMX control selectable for super smooth fades.

- Pulse transformers fired dimmers will dim most types of loads. See section 10.
- 100% duty cycle operation across all channels simultaneously.
- CE, C tick and UKCA approved.

1.2.2 GEN-VI Control Philosophy

Each channel can be independently set to dim mode (with a selection of standard dimming curves in either 8-bit or 16-bit accuracy) or relay mode (TruPower) for direct power switching.

The control source for each channel can be either,

DMX Only. Channels configured for “DMX Only” are controlled by the DMX slot to which they have been patched. If the DMX signal fails, the channels can either hold their last state or after a programmable delay time, fade to a “DMX Loss Memory” previously stored in the GEN-VI.

Every DMX controlled channel can be set to be either a dimmer or a “Trupower” switch. When set to Trupower,

- The channel will switch ON when the DMX signal exceeds 60%.
- The channel will switch OFF when the DMX signal drops below 40%

Auto Power. Channels configured for “Auto Power” are switched on when the lighting console is turned on and a valid DMX signal is detected on the input to the GEN-VI, regardless of actual DMX levels. Therefore, the lighting, audio and video equipment connected to these channels will be powered up without user intervention. When the console is turned off, the equipment will remain on for a programmable “hold time” and then be automatically switched off. This means there is less chance of some equipment being accidentally left on when not in use, ensuring the maximum service life and a lower power bill.

Global control of “Auto Power” can be enabled/disabled.

See section 2 “Quick Start Guide” for details on how to change channel modes.

Channels can also be controlled from the touch screen by selecting **Riggers Control**. See section 5.5.

2 Quick Start Guide

2.1 DMX Address

To patch all of the channels in one GEN-VI rack to sequential DMX slots use the **View Mode** button to select the “DMX Address” home page.

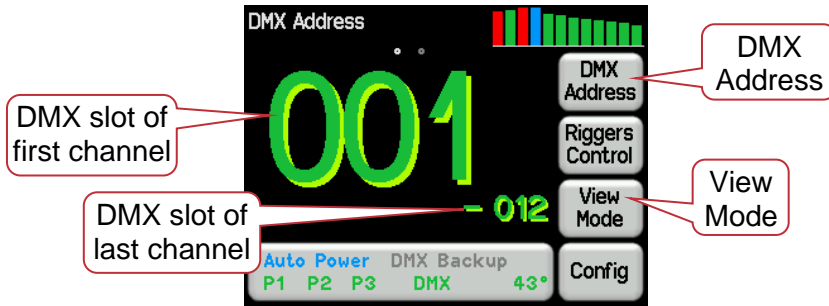

Press **DMX Address**.

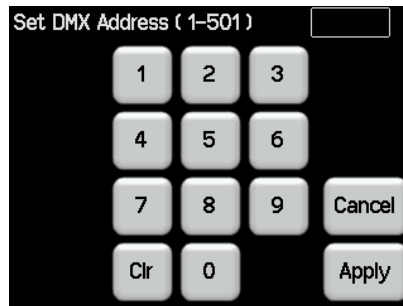

Enter the DMX address for the first channel in this GEN-VI then press **Apply**. All channels will be patched to sequential DMX slots.

Note: GEN VI channels can be individually patched to any DMX slot. See section 5.8.1.

2.2 Channel Modes

Each GEN-VI channel can be configured to be either,

- A DMX controlled dimmer
- A DMX controlled switch (TruPower)
- An “Auto Power” switch (turns on when a DMX signal is present)

2.2.1 Dimmer or TruPower (Switch)

Channels set to Dimmer or TruPower (Switch) are controlled by the DMX level of the DMX slot to which they are patched.

A channel set to TruPower (switch) will switch ON when its DMX signal exceeds 60% and switch OFF when its DMX signal drops below 40%.

To set a channel to be a dimmer or a switch, from either home screen select **Config, Dim/TruPower**.

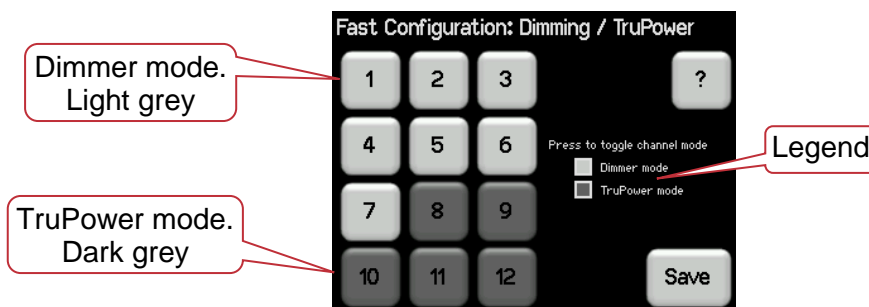

Press a channel number to toggle its mode between “Dimmer” mode and “TruPower” (switch) mode. A light grey button indicates dimmer mode and a dark grey button indicates TruPower mode as shown in the “Legend”.

Configure your channels then press **Save**.

*Note: Changing a channel from TruPower to Dimming mode can potentially damage connected equipment that should not be connected to a dimmed output. If you change a channel from TruPower to Dimming you will be asked to **Confirm** your changes.*

2.2.2 Auto Power

Channels configured for “Auto Power” are switched on when a valid DMX signal is detected on the input to the GEN·VI, regardless of actual DMX levels. When the DMX signal ceases, the channels will switch off after a user programmed time.

“Auto Power” can only be selected if the channel is set to “TruPower” mode. See above.

To set a channel to “Auto Power” mode, select **Config, Channels**, select the channel number(s) then select **Edit** and use the “Parameter Selector” buttons to select the “Source” parameter.

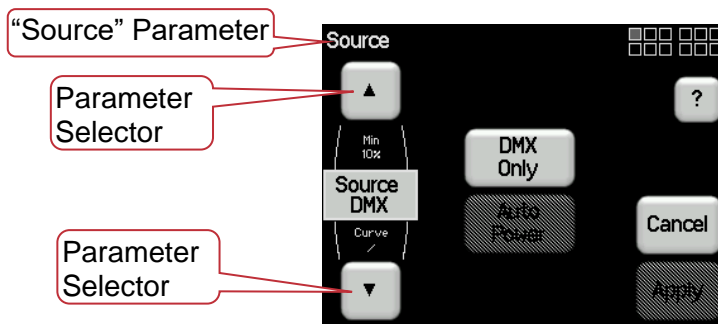

Once “Source” is selected, the choose **Auto Power** then select **Apply**.

Control of all “Auto Power” channels can be disabled or enabled. From either home screen press **Config, DMX**.

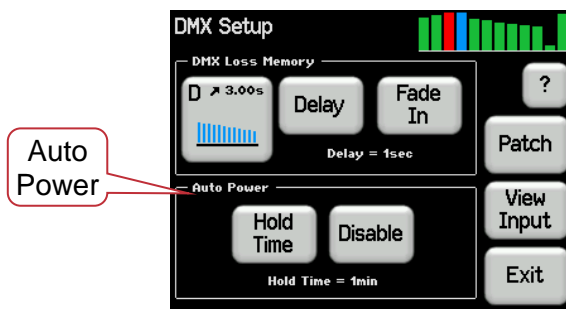

In the “Auto Power” pane press **Disable**. When disabled, the button becomes **Enable**.

Press **Hold Time** to set the time that the “Auto Power” channels will stay ON after the DMX signal is lost.

3 Models

The GEN-VI rackmount is available in the following models,

- 12 channels at 10 amps per channel.
- 12 channels at 16 amps per channel. Not available for sale in Australia or New Zealand.
- 6 channels at 25 amps per channel.
- 3 channels at 63 amps per channel (Film model).

The GEN-VI wallmount is available in the following models,

- 12 channels at 10 amps per channel.
- 6 channels at 25 amps per channel.

3.1 Front Panels

3.1.1 Rackmount GEN-VI

The front panel contains the DMX input and through connectors, load RCBO's (Residual Current Breaker (RCD/GFI) with Overcurrent and Neutral disconnect), SD card slot (used for software upgrades) and LCD touch screen.

Do not use sharp objects to operate the touch screen!

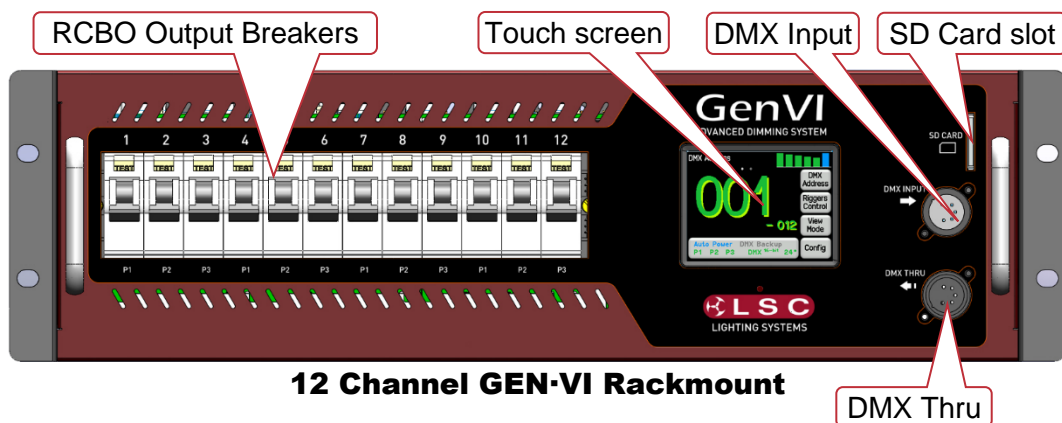

3.1.2 Wallmount GEN-VI

The front panel contains load RCBO's (Residual Current Breaker (RCD/GFI) with Overcurrent and Neutral disconnect), LCD touch screen. The DMX connectors and SD card slot are located on the side of the unit.



12 Channel GEN-VI Wallmount with front outlets



6 Channel GEN-VI Wallmount with internal output terminals

3.2 Output Connectors

Various output connector options are available. See section 11 for details.

4 Installation

4.1 Safety

All electrical work must be carried out by suitably qualified persons.

4.2 Unpacking

The GEN·VI dimmer is fully tested and inspected before leaving the factory. Upon delivery, inspect the dimmer for signs of damage or mishandling. In the event of any damage, contact your LSC agent.

4.3 Installation

4.3.1 Rackmount GEN·VI

The Rackmount GEN·VI is designed for mounting in a standard 19 inch rack. It occupies 3RU (Rack Units) of space. Provide adequate support for the dimmer. The dimmer weighs up to 21Kgm (depending upon the model). The ventilation holes on the sides of the unit must be kept clear.

4.3.2 Wall-mount GEN·VI

The wall-mount version is comprised of two sections. The front section (containing all of the electronics) is attached to the rear section by two hinges located at the bottom and the front section can be completely detached from the rear section to allow better access to the mounting points and the supply and load cable terminations. This also allows the rear section to be mounted and connected whilst the front section is safely stored until all other trades have completed their work and the area is safe and clean. The front section can be opened by removing the 4 large screws as indicated below.



To completely detach the front section, remove the 4 large screws as shown above then unfold the front section. Use a 10mm spanner to remove the 2 nuts holding the metal support straps and lift the straps off the bolts. Replace the nuts to retain the fibre washers. Carefully unfold the front section to the fully open position.

Remove 10mm nut

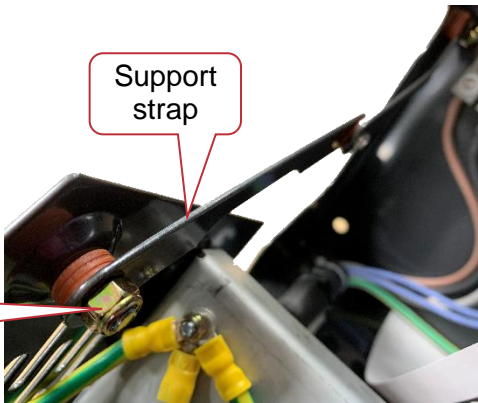

Disconnect the 3-phase cable to the front section from the input terminal block on the rear section and un-bolt the earth connection. Cut the cable tie that secures the 3-phase input cable

Disconnect 3-phase power and earth that feeds the front section

Cut cable tie

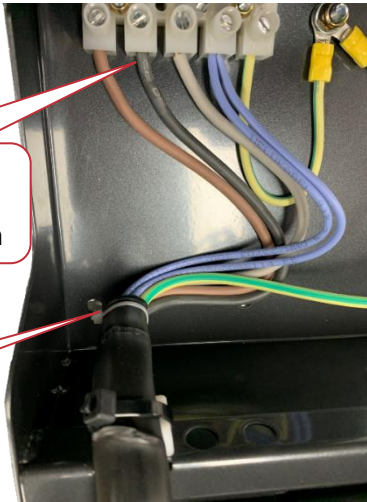

For hardwired output versions only

10-Amp output versions

Un-plug the load connector plugs from the load terminal blocks on the rear section. These connections are tight and will need to be prised out.

Load connector plugs shown partially disconnected

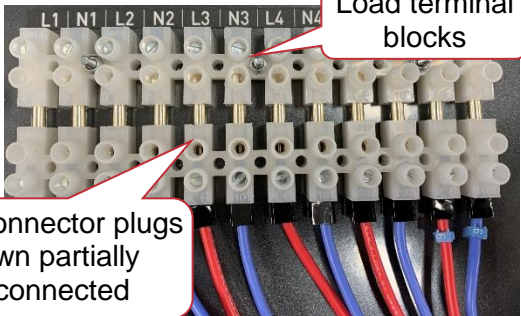

25-Amp output versions

Remove the load terminal block by undoing the nuts that secure the terminal block to the rear section.

The front section can now be removed from the rear section by sliding it sideways off the split hinges.

The rear section has provisions for mounting to walls and other upright structures such as uni-strut. Mounting brackets for P1000 Uni-Strut are available from LSC.

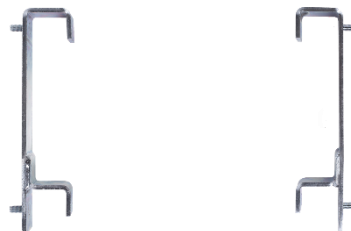

Uni-Strut brackets

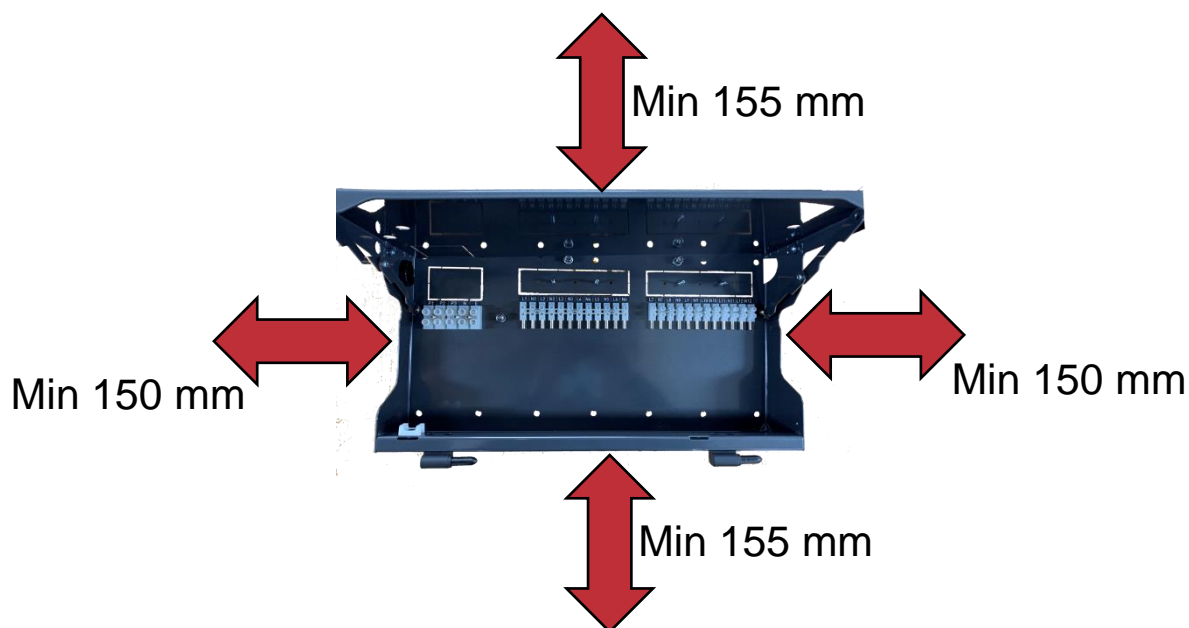

GEN-VI Wall Mount Rear Section

Allow a minimum of 150mm clearance on either side of the dimmer to provide adequate ventilation and 155mm vertical clearance to allow units above and below to be opened.

The dimmer weighs 21.5Kg.

4.3.3 Patch Bay Installation

In conjunction with the Redback patch system, up to 4 x Gen VI wallmount dimmers can be installed each side of the patch bay allowing for 96 channels of dimming/power distro and patch bay to be located in an area of only 1.8m high x 1.7m wide. This combination allows all the user controls to be located within a comfortable working height (between 1.8m and 1m) and ensures that no patch cables touch the floor.

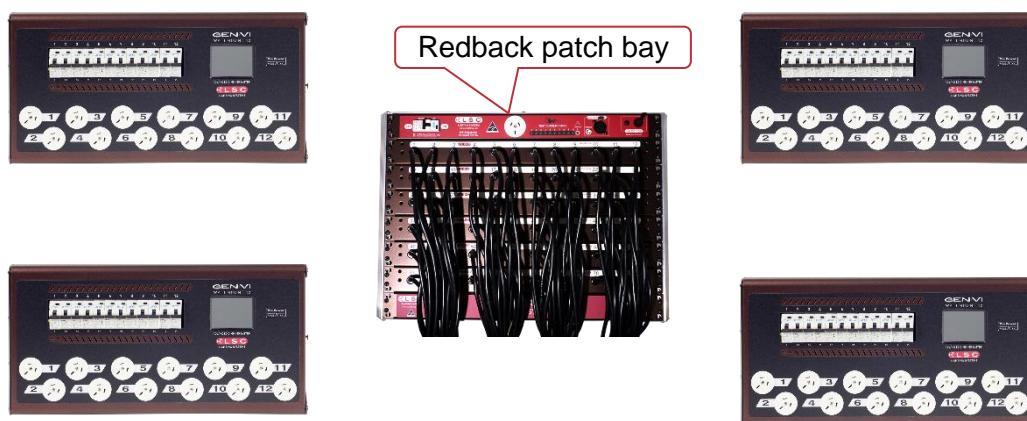

Typical 48 channel installation with Redback patch bay

4.4 Connections

4.4.1 Input Power Supply

The GEN·VI dimmer must be fed from a suitable protected power source of 63 Amps maximum per phase. Lower current supplies can be used for the 10Amp and 25Amp models as listed below.

Note: The rating of the Neutral conductor feeding the dimmer must be at least 1.25 times that of rated limit of any of the Active phase conductors. For example, a 40Amp 3 phase supply must have a neutral rated at 50Amps. This is because various combinations of dimmer drive can result in a Neutral current higher than the line current due to the phase control characteristics of these type of dimmers.

The nominal input voltage is 110-120 / 220-240 Volts. 3-phase + Neutral (208V / 415V P-P) 50/60Hz + Earth. The GEN·VI can be powered from any of the following sources;

- Three phase supply of nominal 230-240V 3N~ 50/60Hz of up to:
 - 40 Amps per phase – 12 x 10A dimmers
 - 50 Amps per phase – 6 x 25A dimmers
 - 63 Amps per phase – 12 x 16A dimmers or 3 x 63A dimmers
- Three phase supply of nominal 110-120V 3N~ 50/60Hz of up to:
 - 40 Amps per phase – 12 x 10A dimmers
 - 50 Amps per phase – 6 x 25A dimmers
 - 63 Amps per phase – 12 x 16A dimmers or 3 x 63A dimmers
- Single phase supply of nominal 110-120V 3N~ 50/60Hz of up to the rated current of the Neutral conductor, or 63 Amps whichever is lower.
- Single phase supply of nominal 220-240V 3N~ 50/50Hz of up to the rated current of the Neutral conductor, or 63 Amps whichever is lower.

Safety Note: Conversion between three phase and single phase operation should only be undertaken by a suitably trained and qualified electrical technician.

4.4.2 Wallmount GEN·VI Power Input Options

There are a number of possible entry points to connect the incoming three phase supply,

- For hard-wired installations, there are two large knock-out panels located on the upper left hand region. These knock-out panels allow wiring to enter and exit the dimmer via cable ducting on top or direct through a wall cavity at the rear.
- For portable or installation situations where a flexible three phase tail and plug are required, a 32mm diameter hole exists on the upper left side. A hole plug is supplied to cover this hole when the product is shipped. By removing this plug, a correct size metal or plastic strain-relief gland can be fitted to secure the three phase tail to the chassis.

4.4.3 DMX512 Connections

DMX 512 is the industry standard for the transmission of digital control signals between lighting equipment. DMX is usually “looped” from one piece of equipment to the next. DMX 512 is connected to the dimmer via the 5 pin XLR “DMX INPUT” socket. A “DMX THRU” socket provides a loop output to feed other DMX equipment.

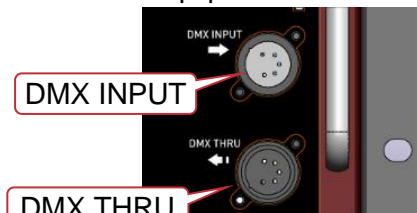

Rackmount

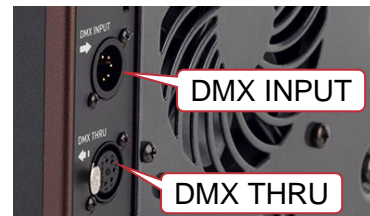

Wallmount

If the DMX line ends at this dimmer (is not looped to other dimmers or devices) then the DMX TERM switch must be set to TERM using the touch screen. See section 5.9. LSC recommends the use of RS485 data cable or shielded CAT5 cable for the DMX connections. Audio or Microphone cables must not be used.

5 Configuration and Operation

5.1 Overview

The GEN-VI dimmer uses a touch screen with menus on the screen that provide the functions to configure and operate the dimmer.

5.2 Help Screens

Several menus have Help screens available. Press the button (when available) to see the help screen. Press anywhere within the help screen to cancel.

5.3 Home Pages

There are two “home” pages that can be selected. Pressing **View Mode** changes the display between the “DMX Address” home page and the “Dimmer Output” home page. Both home pages provide access to the “Riggers Control” and “Config” menus.

5.3.1 DMX Address Home Page

The “DMX Address” home page has two formats,

- If a 1 to 1 patch is implemented (via the “DMX Address” button) it shows the DMX addresses of the first and last channels of the dimmer (in a large and small font respectively)

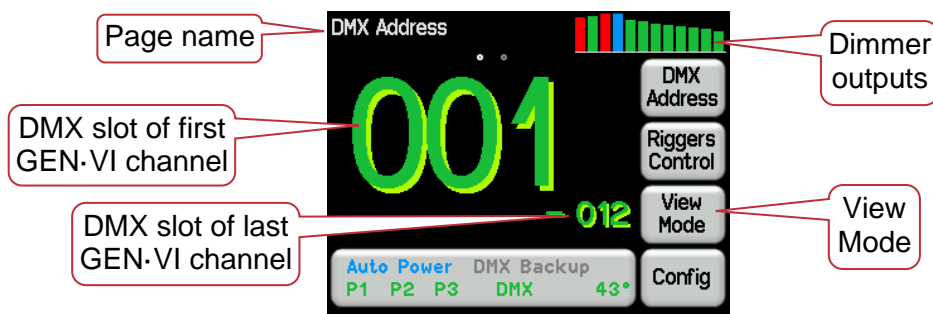

“DMX Address” Home Page with 1 to 1 Patch

- If channels are individually patched it shows the word “Patched” and the DMX addresses of all channels in the dimmer

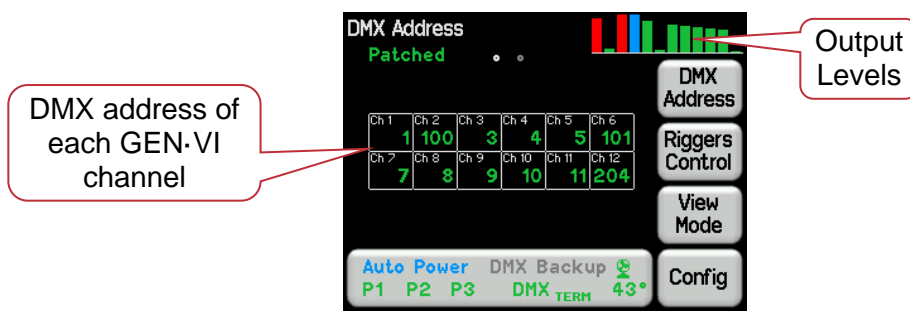

“DMX Address” Home Page with channels individually patched

Individual channel patching is performed in the DMX menu. See section 5.8

Both displays also show a colour coded mini bar-graph of the dimmer output at the top of the screen. See the “Dimmer Output” home page below for the colour code of the bar graph.

5.3.2 DMX Address

Patches are often performed in contiguous blocks of addresses. The “DMX Address” button provides a rapid method of patching all of the channels in one GEN·VI rack to sequential DMX slots, starting from a DMX address that you enter. This is commonly known as a 1 to 1 patch.

To perform a 1 to 1 patch, select the “DMX Address” home page (above) then press **DMX Address**.

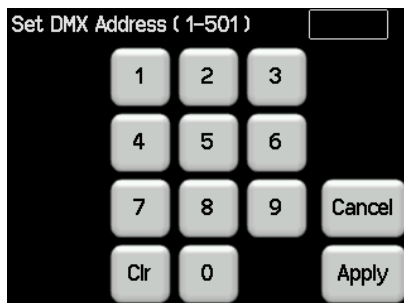

Enter the DMX address for the first channel in this GEN·VI then press **Apply**.

5.3.3 Dimmer Output Home Page

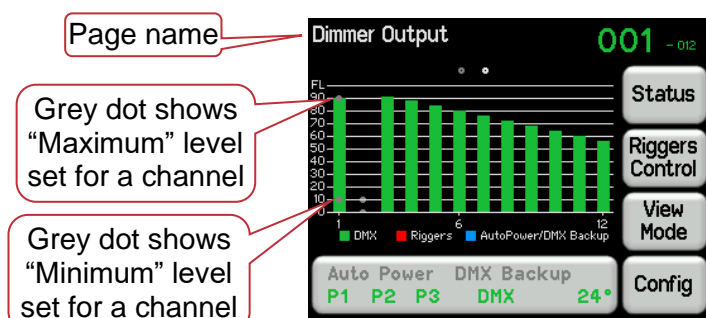

“Dimmer Output” Home Page

The “Dimmer Output” home page has a large display of output levels of the dimmer channels that also shows the control source of each channel according to the colour code.

- Green = DMX control
- Red = Rigger control (via the touch screen)
- Blue = Auto power or DMX Backup (DMX loss) memory

Channels are controlled on a HTP (highest Takes Precedence) basis. If multiple sources are controlling a channel (such as DMX and Riggers control) then the highest level will be output and will hence determine the colour of the bargraph.

If a minimum or maximum level has been set for a channel, they are indicated by grey dots on the channels bar-graph. The output is scaled between the minimum and maximum levels.

The top right corner of the screen shows the DMX address information.

- If a 1 to 1 patch is implemented it shows the DMX addresses of the first and last channels of the GEN·VI rack
- If channels are individually patched it shows the word “Patched”

The “Dimmer Output” home page also and provides access to the **Status** menu.

5.3.4 Status

On the “Dimmer Output” home page, pressing **Status** shows the following information....

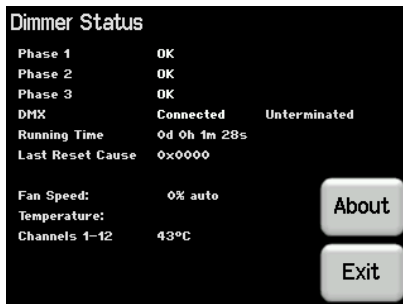

It shows the presence of the input power phases, DMX presence, the current setting of the DMX termination, dimmer running time, last cause of a reset, internal temperature and the fan speed and fan setting (constant speed or automatic).

Pressing **About** shows the software versions, RDM ID and the optional “Owner” name. See section 9 for more information about RDM.

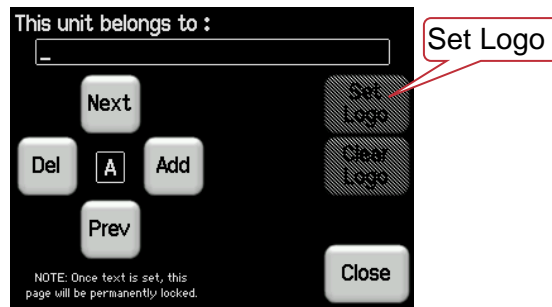

5.3.5 Owner

Warning: If you enter an owner name and or logo and press “Lock”, this is permanently locked and can only be changed by an authorised LSC dealer. You must set the name and logo before pushing Lock. Once Lock has been pressed, the name and logo cannot be changed without contacting the factory. This acts as a deterrent against theft of your APS.

Pressing **Owner** allows you to enter a permanent name for the dimmer (“This unit belongs to:”) as a deterrent against theft. The “Owner” menu also allows you to set a “Logo” that will be momentarily displayed when power is applied to the GEN-VI instead of the LSC logo.

To enter an owner name, use the **Next** and **Prev** buttons to select a character then **Add** to enter the character or **Del** to delete a character.

To set a custom logo a special file must be present on an SD card inserted in the APS. There is a fee for LSC to convert your logo into the special file that will load into your APS. Please contact LSC or your LSC agent for details.

When the owner name and/or logo have been entered, the Exit button changes to “Lock”. To permanently lock in your changes press **Lock**.

5.4 Dimmer Status

The large button at the bottom of both home pages shows the status of the following...



- **Auto Power** shows the status of channels set to “Auto Power”. These channels will be switched on whenever DMX is present. See section 5.8.4
Blue is On. Grey is Off.
- **DMX Backup** is the “DMX loss” memory. See section 5.8.3
Blue is active. Grey is not active.
- **P1, P2, P3** show the presence of the input power phases.
Green indicates power is present. Flashing red is not present.
- **DMX** shows the presence of a DMX control signal.
Green is DMX present. Flashing Red is not present.
- **16-bit** indicates that DMX control is using 16-bit resolution. See section 5.8.2
- **TERM** indicates that the DMX line is terminated by the GEN·VI dimmer. See section 5.9
- The GEN·VI has an internal cooling fan. The animated fan symbol is displayed when the fan is running. The fan speed can be controlled. See section 0. The letter “C” is displayed beside the fan symbol if the speed has been set to “Constant”.
- The internal temperature of the GEN·VI is shown in degrees Celsius. The colour warns you if the temperature is too high.
 - At normal temperatures the display is green.
 - At 65C the display turns yellow.
 - At 75C the display turns red.
 - At 85C it flashes red.
 - At 90C the ALL OUTPUT is automatically switched OFF.

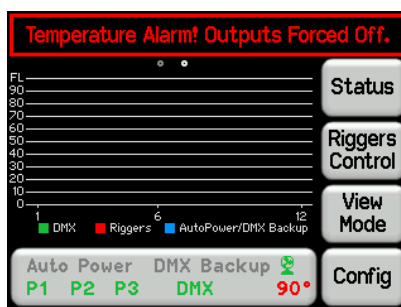

Either reduce the load or increase the cooling to reduce the temperature. If the fan has been set to a constant slow speed either increase the speed or set it to “Automatic”. See section 0.

When the temperature drops below 86 degrees the outputs are automatically switched back on. If the fan is set to “Constant Speed”, the fan will automatically run at full speed if the temperature exceeds 65 degrees.

Touching  shows the legend for the display.....

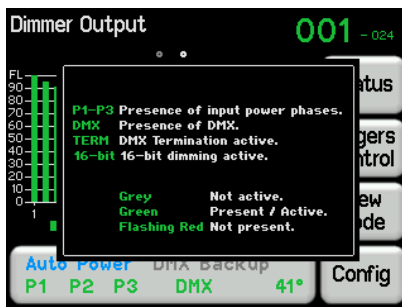

Touch anywhere within the legend window to close.

5.5 Riggers Control

To set the level of a channel(s) (or run a chaser) from the touch screen, from either home page (above) press **Riggers Control**.

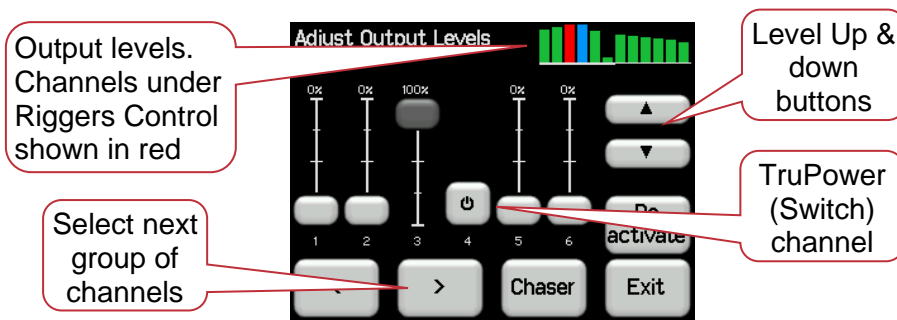

The output of the Riggers Controls can be turned off or on by pressing: **De activate/Activate**. Channels are controlled on a HTP (highest Takes Precedence) basis. If multiple sources are controlling a channel (such as DMX and Riggers Control) then the highest level will be output.

To set the level of a channel(s), use the virtual faders or touch a fader then use the ▲ or ▼ buttons. “TruPower” channels have an On/Off push button switch instead of a fader. The button turns green when it is on. Press < or > to select more channels. When finished press **Exit**.

5.5.1 Chaser

To activate the chaser, from the “Rigger Control” (above), press **Chaser**.

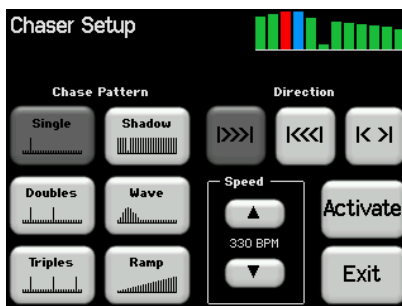

To enable the Chaser, press **Activate**.
 Select a pattern using the 6 “Chase Pattern” buttons.
 Set the speed in BPM (Beats Per Minute) by pressing the ▲ or ▼ buttons.
 Use the “Direction” buttons to select **I>>>|** (forward), **I<<<|** (reverse) or **I<>|** (bounce from end to end).
 To disable the Chaser press, **De-Activate**.
 When finished press **Exit**.

5.6 Config Menu

From either home page, pressing **Config** allows you to access a range of functions and setups via sub-menus.



If the GEN·VI has been “locked”, the **Config** button is replaced by the **Padlock** button.



Touching the **Padlock** button and entering your code number unlocks the GEN·VI and reveals the **Config** button. See section 5.12 for details on how to lock and unlock the GEN·VI.

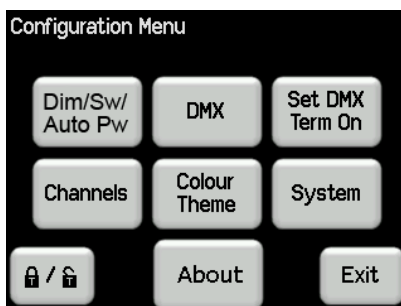

The following table shows the functions that can be performed in each sub menu. Each button is described in detail in the following sections.

Dim/TruPower	DMX	Set DMX Term
Fast Configuration of either Dimming or TruPower (switched) for each channel.	Patch View DMX Input levels Edit DMX Loss Memory & Delay Time Fade In/Out DMX Loss memory Enable Auto Power Auto Power Hold Time	Terminates the DMX line. On/Off
Channels	Colour Theme	System
Min Level Max Level Curve Source	Antarctic Dawn Redback Gothic	Code Upgrade Reset Fan Control Import/Export
Lock	About	Exit
User Service	Software versions + RDM ID	

5.7 Dimmer or Trupower (Switch)

Each channel can be individually configured to be either a dimmed channel or a Trupower (switched) channel.

Switched channels use LSC’s “TruPower” technology that provides direct power by utilising relays, guaranteeing there are absolutely no electronics in the circuit to interfere with connected loads.

“TruPower” is used for devices that do not fade, but need to be switched OFF or ON such as motors, discharge lamps and some LED fixtures.

- When the control signal exceeds 60% the Trupower channel will switch ON.
- When the control signal drops below 40%, the Trupower channel will switch OFF.

Selecting **Config, Dim/TruPower** provides a rapid means of for configuring channels as either “Dimming” or “TruPower”.

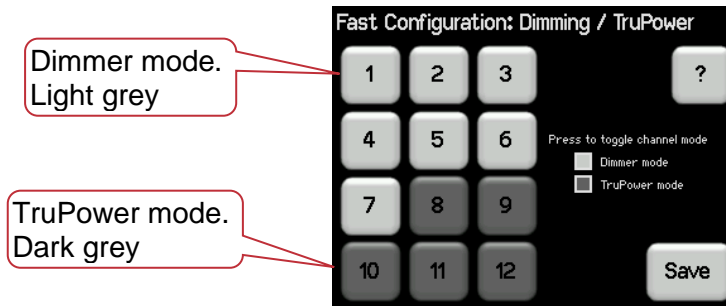

Press a channel to toggle its mode between “Dimmer” mode and “TruPower” mode. A light grey button indicates dimmer mode and a dark grey button indicates TruPower mode. Configure your channels then press **Save**.

Note: Changing a channel from TruPower to Dimming mode can potentially damage connected equipment that should not be connected to a dimmed output. If you change a channel from TruPower to Dimming you will be asked to **Confirm** your changes.

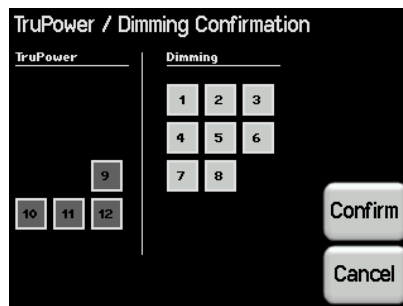

If you change a channel from Dimming to TruPower, no confirmation is required and the changes will be applied when you press **Save**.

Note: that channels can also be changed between Dimming and TruPower in the “Channels” menu with more options available. See section 5.10

5.8 DMX Menu

Selecting **Config, DMX** provides menus for,

- Patching DMX.
- Editing and activating the DMX Loss (D) memory.
- Enabling and time setting the Auto Power function.
- Viewing the Input DMX signal.

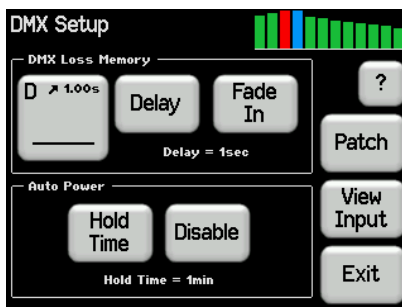

5.8.1 Patch

Each GEN·VI dimmer unit numbers its channels from channel 1 through to channel 12. The patch menu allows you to patch (connect) DMX slots (addresses) from your DMX lighting controller to GEN·VI channel numbers. Patches are often performed in contiguous blocks of addresses.

*Note: The **DMX Address** button on the “DMX Address” home page provides a rapid method of patching all of the dimmers in one GEN·VI unit to sequential DMX slots, starting from a DMX address that you select. See section 5.3.2*

The “Patch” menu allows you to individually patch dimmers channels to DMX slots. Individual patches are required when,

- A particular *DMX slot number* from the lighting controller is to control a particular GEN·VI dimmer *channel number*.
- A single DMX slot number is to control multiple GEN·VI channel numbers.

To individually patch dimmers channels to DMX addresses press **Config, DMX, Patch**.

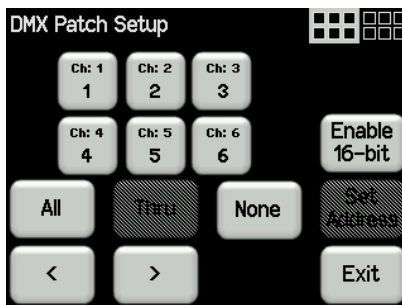

The menu shows the first 6 channels. Use the < or > buttons to see the other groups of 6 channels. Touch a channel to select it. You can select multiple channels. To select a range of channels select your first channel then press **Thru** then your last channel. Use **All** to select all channels. Press **None** to de-select all channels.

When you have selected your channel(s) press **Set Address**.

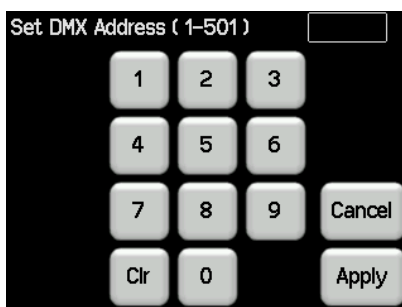

Enter the required DMX address then press **Apply**.

If more than one channel is selected, then the lowest channel number will be patched to the selected DMX slot and the following dimmers will be patched to the sequential DMX slot numbers. For example, if channels 1, 2, 3 and 10 are selected and DMX slot number 24 is applied the result will be:

Channel	DMX Slot
1	24
2	25
3	26
10	27

To patch multiple channels to the same DMX slot patch them one at a time.

When finished patching press **Exit**.

If dimmer channels have been individually patched, then the “DMX Address” home page displays a table showing the patches. For example:

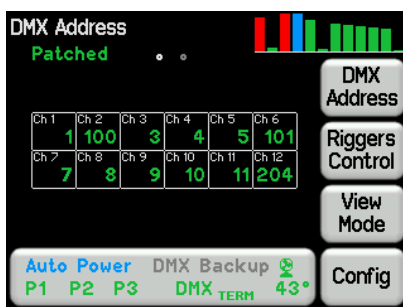

5.8.2 16 Bit DMX Control

The DMX512-A signal contains the level information for 512 DMX slots (addresses). The level for each slot is sent in 8 bits of data which gives a maximum resolution of 256 discrete levels between off and full on. If you require smoother fades, the GEN·VI dimmer can be set to 16bit mode where each dimmer channel uses 2 DMX slots to control its level. This gives 65536 discrete levels when fading from off to full. Your lighting controller must also support 16 bit dimmers.

To use 16 bit control, from the “DMX Patch Setup” menu (above) press **Enable 16-Bit**. The status area at the bottom of both home pages show you when 16 bit DMX control is selected.

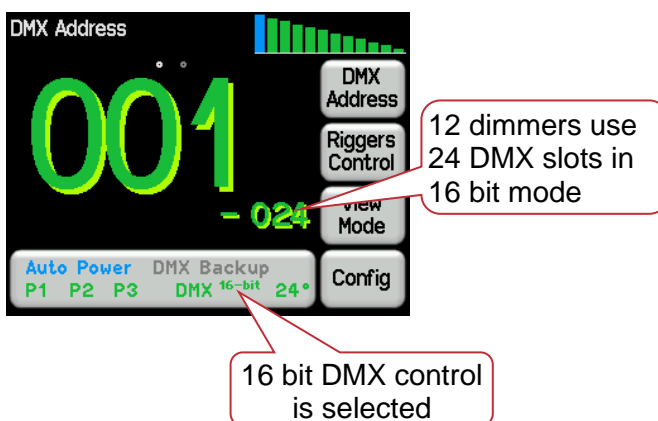

See section 7 for more information on DMX.

5.8.3 DMX Loss Memory

The GEN·VI has a “DMX Loss Memory” that you can program. In the event that the DMX input signal is lost, channels set to DMX control will hold their last DMX level for a programmable “Delay” time. The default setting for this time is “Infinite”. If you set a delay time other than “Infinite”, the channels will fade to the “DMX Loss Memory” when the delay time expires (up to 1 hour). When DMX is restored, the GEN·VI will fade back (in 1 second) to the DMX signal.

To create or edit a “DMX Loss Memory” press **Config, DMX**.

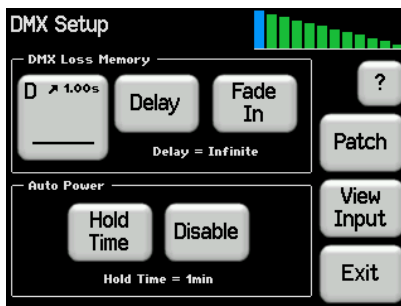

The “DMX Loss Memory” pane has 3 buttons,

- Press  to create or edit the memory as described below
- Press **Delay** to set the time that the GenVI will wait after DMX is lost, until its output fades to the “DMX Loss Memory”
- Press **Fade In/Fade Out** to see the DMX Loss memory on the output (for testing purposes)



The  button shows a bargraph display of the current DMX Loss memory (if any) and also its fade time in seconds. For example,

Bargraph of DMX Loss Memory channel levels

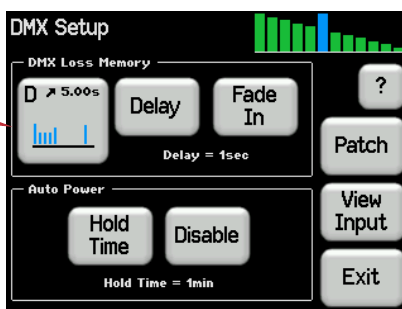

When you press , the “DMX Loss Memory” menu allows you to create or edit the “DMX Loss Memory” by any of the following methods,

- Manually set channel levels using the controls on the screen
- Take a **Snap** (snapshot) of the current DMX input signal
- Take a **Snap** (snapshot) of the current state of the output

Selects next group of 6 channels

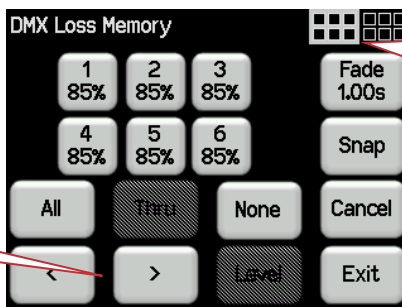

Navigator shows current group of 6 selected channels highlighted

You can also set a fade time for the DMX Loss Memory.

5.8.3.1 Manually Setting Loss Memory Channel Levels

The “DMX Loss Memory” menu (above) shows the first 6 channels. Use the < or > buttons to see the other groups of 6 channels. The navigator at the top right of the screen shows current group of 6 selected channels highlighted.

Touch a channel to select it. You can select multiple channels. To select a range of channels, select your first channel then press **Thru** then your last channel. Use **All** to select all channels. Press **None** to de-select all channels. When you have selected your channel(s) press **Level**.

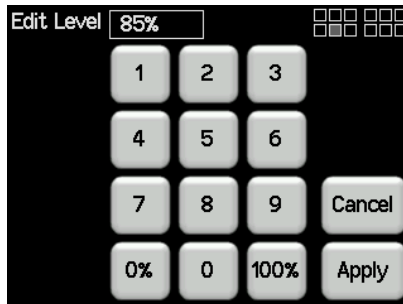

Use the keypad to set the level then press **Apply**.

5.8.3.2 Taking a Snapshot

To create a memory by taking a snapshot, press **Snap** from the “DMX Loss Memory” menu above.

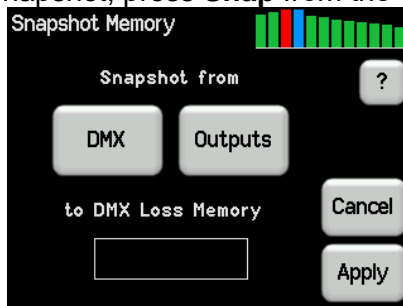

- Pressing **DMX** will take a snapshot of the current DMX input signal
- Pressing **Outputs** will take a snapshot of the current output of the GEN·VI. These channel levels could be coming from DMX or Riggers Control or a combination of both

When you take the snap, the channels levels will be displayed in the box.

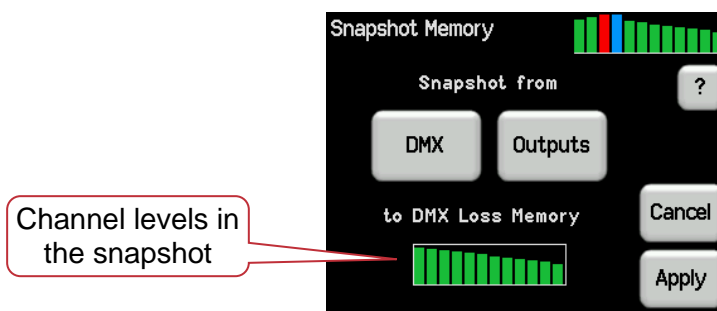

To save the snapshot to the memory press **Apply**.

The channels levels that were captured in the snapshot can be edited by manually setting channel levels as described above.

5.8.3.3 Fade Time

When editing the DMX Loss memory (above), you can set a fade (in/out) time for the memory by pressing **Fade**.

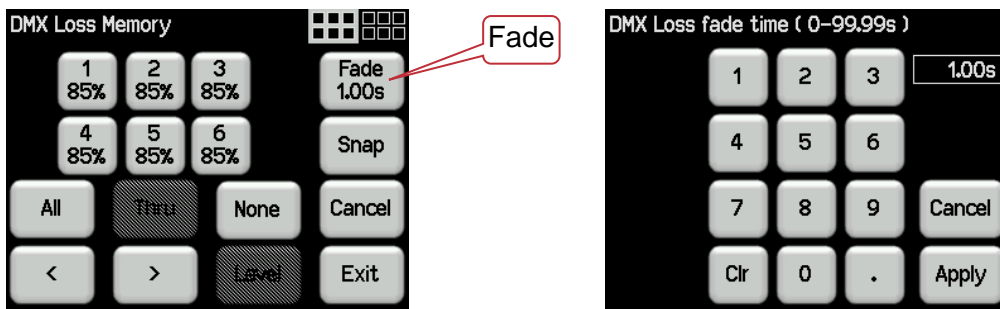

Enter a time in seconds (0.02 to 99.99) then press **Apply**.

5.8.3.4 Fade In/Out

The DMX Loss memory is normally activated automatically when DMX is lost but you can also manually fade the memory in or out using the **Fade In / Fade Out** button.

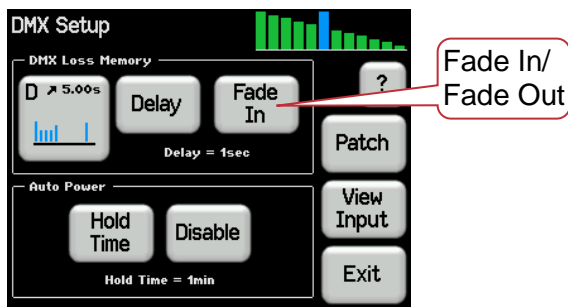

5.8.4 Auto Power Enable and Hold Time

Many lighting fixtures such as LED's and moving fixtures require a constant source of non-dimmed power when they are operating. Normally you would manually switch on the power to these devices prior to a show and manually switch them off at the conclusion. Auto Power is a feature that automatically switches selected GEN·VI channels to ON whenever there is a DMX signal present on the input to the GEN·VI and switches them OFF when the lighting controller is turned off and the DMX signal is not present. A "Hold Time" can be set to prevent fixtures being turned off if there is a short interruption to the DMX signal and also to allow for a cool down period for the fixtures.

In the following example, the 3 moving fixtures require non-dimmed power plus DMX for control. They are connected to a GEN·VI channel that is configured for "TruPower" and "Auto Power". The 2 conventional fixtures are connected to GEN·VI channels configured for either "S Curve" or "L Curve" dimming outputs. When the lighting controller is switched on, the GEN·VI detects the DMX signal and automatically switches on the power to the moving fixtures.

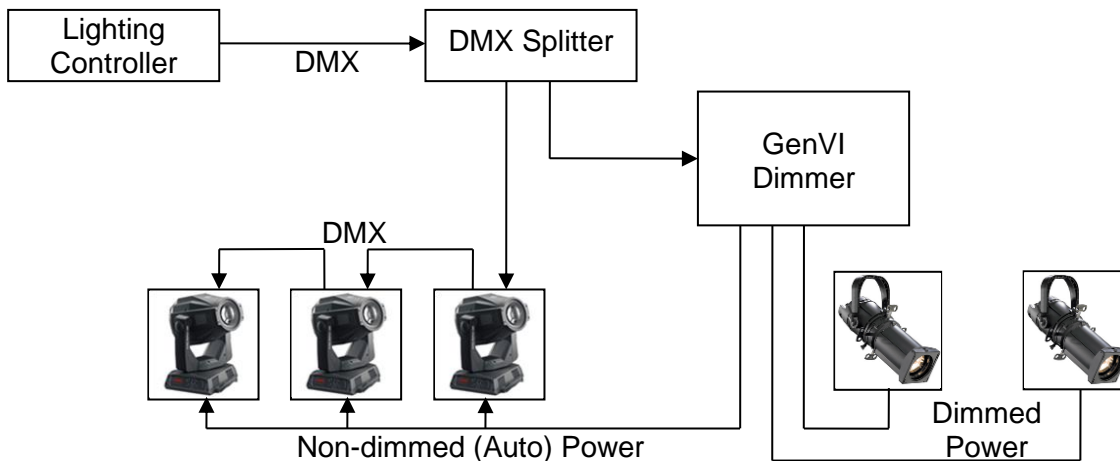

To enable "Auto Power", from either home screen press **Config, DMX**.

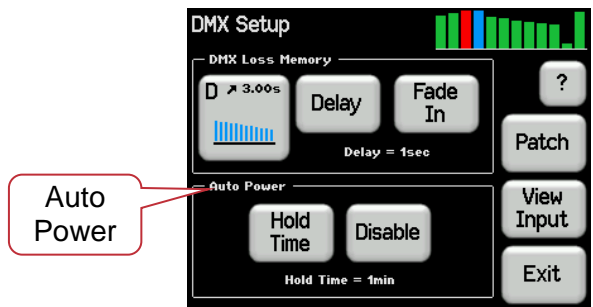

The “Auto Power” pane has 2 buttons,

- Press **Disable** to disable the Auto Power function. The button then changes to **Enable**. This is a global setting for all channels that have their control source set to “Auto Power”. See below for details on how to set a channel to “Auto Power”
- Press **Hold Time** and enter a time from 1 to 60 minutes. This is the time that the “Auto Power” channels will stay ON after the DMX signal is lost

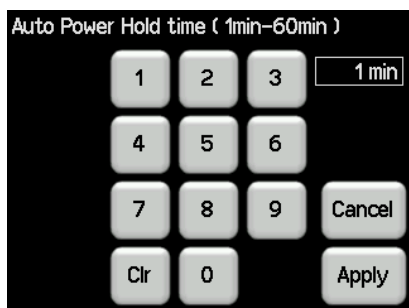

5.8.5 Auto Power Mode

To set a channel to operate in “Auto Power” mode you must first set the channel to “TruPower” mode and then set its “Control Source” to “Auto Power”.

- To set a channel to “TruPower” mode, from either home screen select **Config, Dim/TruPower**

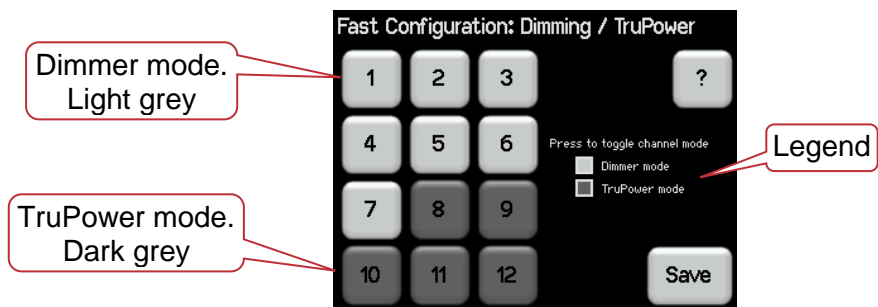

Press a channel number to toggle its mode *between* “Dimmer” mode and “TruPower” (switch) mode. A dark grey button indicates TruPower mode as shown in the “Legend”. Press **Save**.

- To set a channel to “Auto Power” mode, select **Config, Channels**, select the channel number(s) then select **Edit** and use the “Parameter Selector” buttons to select the **Source** parameter.

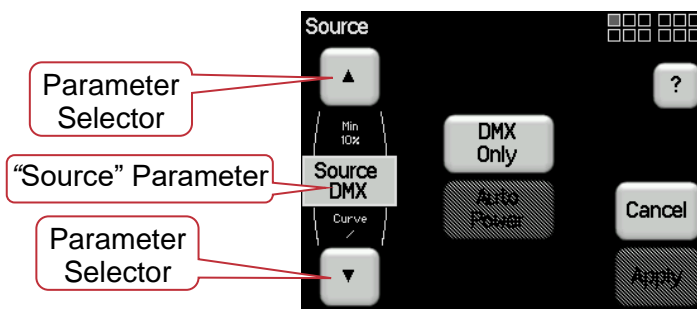

Once “Source” is selected, the choose **Auto Power** then select **Apply**.

5.8.6 View Input

The “DMX Setup” menu allows you to view the channel levels on the DMX input. To view the DMX input press **Config, DMX, View Input**.

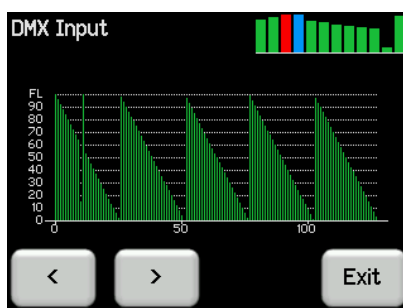

Press either > or < to scroll through all slots in the DMX Universe.

5.9 Set DMX Term

Selecting **Config, Set DMX Term On/Off** switches the internal DMX termination switch On or Off respectively. See section 8 for more details on DMX.

5.10 Channels Menu

Selecting **Config, Channels** provides menus for configuring the following parameters for each channel,

- Min. Minimum Level
- Max. Maximum Level
- Curve. The choices are: S curve dimming, L (Linear) dimming, TruPower or Custom curve dimming
- Source. The control source for the channel. The choices are: “DMX only” and “Auto Power” (Auto Power turns the channel On whenever a DMX signal is present)

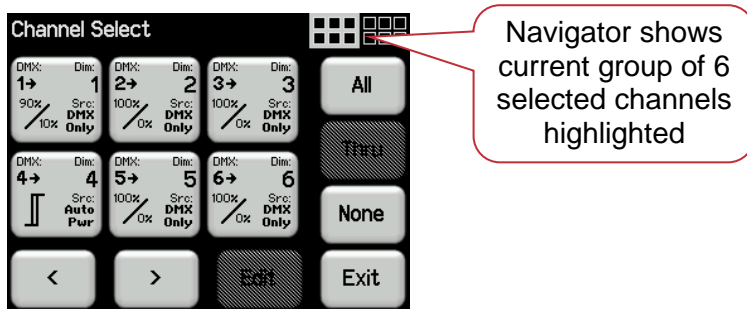

The screen shows the settings for the first 6 channels. Use the < or > buttons to see the other groups of 6 channels. The navigator in the top right of the screen shows the selected group highlighted.

Each channel button shows the settings for that channel. For example:

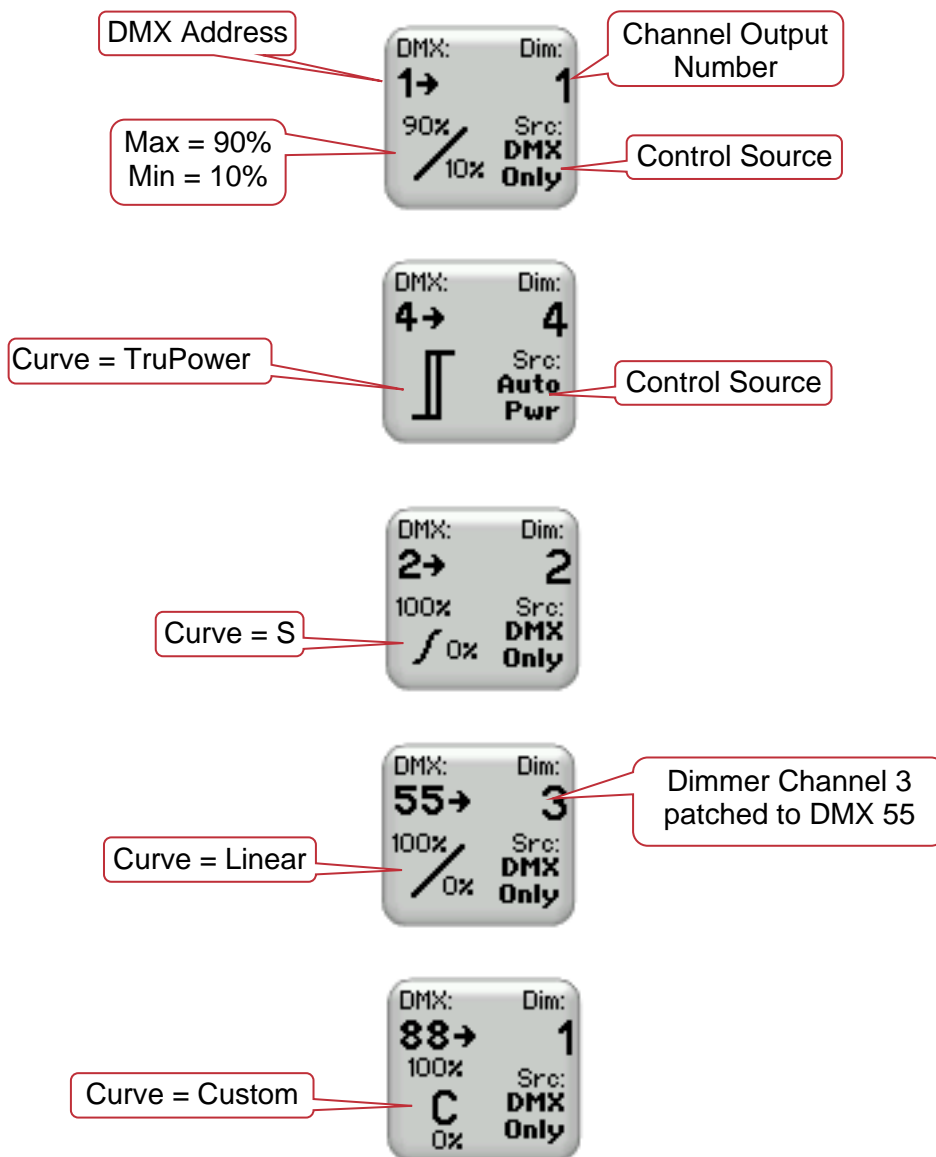

To change the settings of a channel(s), select the channel(s) by touching it. You can select multiple channels. To select a range of channels, select your first channel then press **Thru** then your last channel. Use the < or > buttons to see the other groups of 6 channels. Use **All** to select all channels. Press **None** to de-select all channels.

The selected channels are highlighted in the navigator:

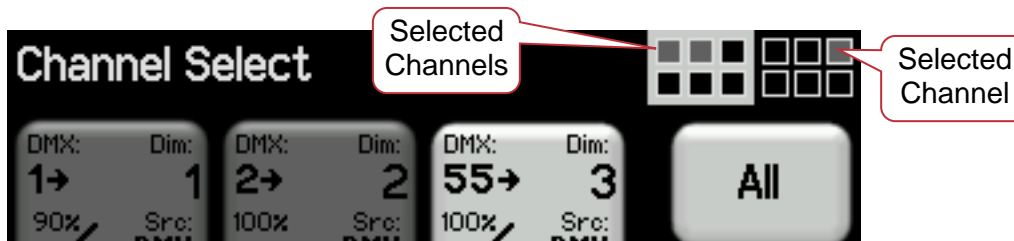

In this example channels 1, 2 and 9 are selected.

When you have selected your channel(s) press **Edit**.

There are 4 possible parameter menus: Min Level, Max level, Curve and Source. Use the ▲ and ▼ “Parameter Selector” buttons to scroll through the parameter settings for the selected channel(s).

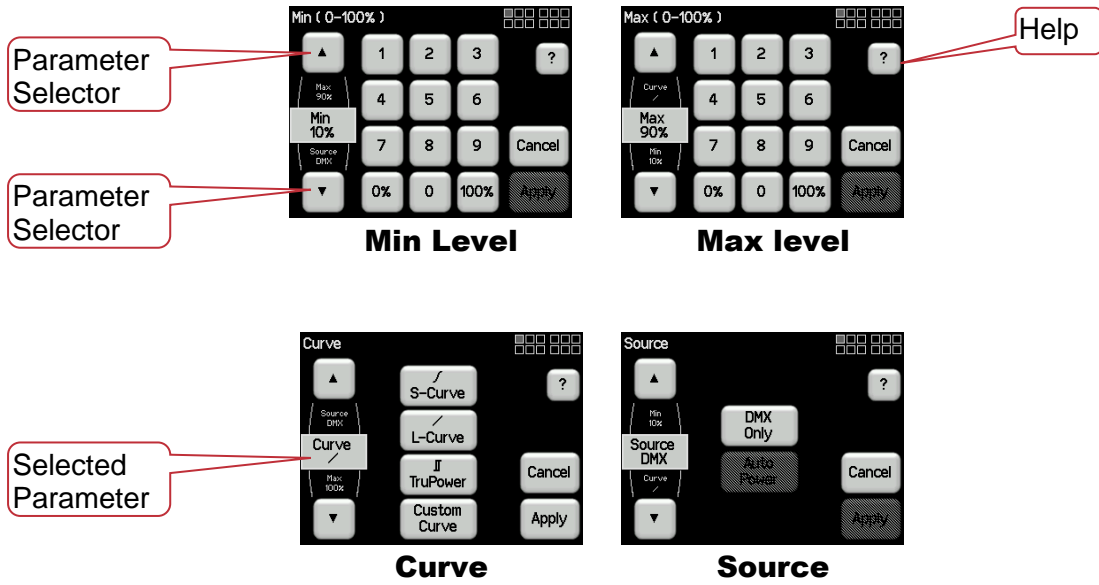

- A channels “Curve” must be set to “TruPower” before “Auto Power” can be selected as the “Source”
- If a channel is set to “TruPower” then the Min and Max settings are not available and any Min or Max settings that may have been made are ignored



Each parameter setting is described below and on screen help also explains each parameter.

5.10.1 Min Level

Select **Config, Channels**, select the channel number(s) then **Edit** and select the **Min Level** parameter.

“Min” sets the level of the channel output when the control signal is set to minimum. For example, setting this value slightly above zero is useful to “Pre-Heat” lamp filaments. “Min level” is disabled in “Tru Power” mode.

5.10.2 Max Level

Select **Config, Channels**, select the channel number(s) then **Edit** and select the **Max Level** parameter.

“Max” sets the level of the dimmer output when its control signal is set to maximum. For example, setting this value to 90% will extend the life of a lamp as it never operates on full voltage or setting it to 50% provides 115 volt output.

Note: The actual output voltage is dependent upon the dimmer curve. LSC recommends that you measure the output voltage (with a 240 volt load connected) to determine the “Max” level setting you require for a specific maximum voltage. This procedure should only be carried out by suitably qualified personnel.

“Max level” is disabled in “Tru Power” mode.

5.10.3 Curve

Select **Config, Channels**, select the channel number(s) then **Edit** and select the **Curve** parameter. Fade Curve is the curve or “transfer characteristic” between input control signal and dimmer output.

The following curves are available,

- **S curve.** Provides a normal response between control signal input and dimmer output
- **Linear curve.** Provides a linear response with more output at the lower end
- **TruPower.** GEN·VI “TruPower” output provides switched power by utilising relays, guaranteeing there are absolutely no electronics in the circuit to interfere with connected loads. When the control signal exceeds 60% the channel will switch from OFF to full ON. When the control signal drops below 40%, the channel will switch OFF. “TruPower” is used for devices that do not fade, but need to be switched OFF or ON such as motors, discharge lamps and LED fixtures. Min and Max level are not available when TruPower is selected. Channels can also be quickly configured as “Dimming” or “TruPower” in the “Dim/TruPower” menu. See section 5.7
- **Custom curve.** The custom curve is provided for special dimming cases. One LSC custom curve is included with the GEN·VI dimmer. It is suitable for dimming LEDs. You can export the LSC custom curve and modify it to your own requirements. To do so, insert a SD card into the slot then select: **Config, System, Import/Export, Export Curve.** Transfer the “CURVE.DAT” file from the SD card to a computer. The file is a text file that you can open in any text editor or spreadsheet program. It has one entry per line indicating output level (0-65535) for each of 256 DMX input values (0-255). If you want to visualise and/or manipulate the data, select the whole file in your text editor, copy the contents and paste it into a column in a spreadsheet program then create a graph from that data series

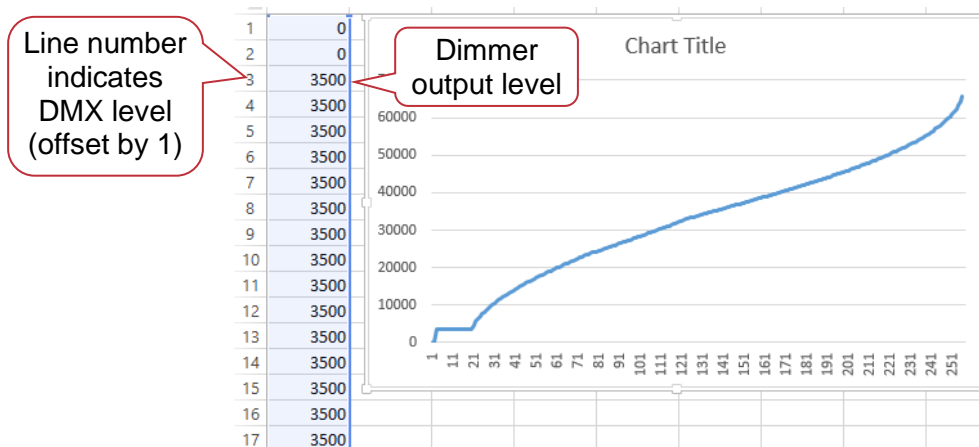

LSC custom curve opened in a spreadsheet with a line chart inserted

For example, if DMX input level is 2 then you look at line 3 (because DMX values start at 0) and you get the output level of the dimmer of 3500. You can change the shape of the curve by changing the dimmer output levels for each associated DMX input level. Using a spreadsheet with a chart displayed makes it easy to see the new curve because the chart changes in real time as you change the output levels.

When you have made your changes in the spreadsheet, save the file as CURVE and in the “Save as type” box select “Unicode Text (*.txt)”. Close the spreadsheet program then use your computer to change the file name from “CURVE.TXT” to “CURVE.DAT”. Only one “CURVE.DAT” file can exist so you must over right the original file.

To import your custom curve, copy the file to an SD card, insert the card in the GEN·VI then select: **Config, System, Import/Export, Import Curve.**

5.10.4 Source (DMX or Auto Power)

Select **Config, Channels**, select the channel number(s) then **Edit** then use the “Parameter Selector” buttons to select the “Source” parameter.

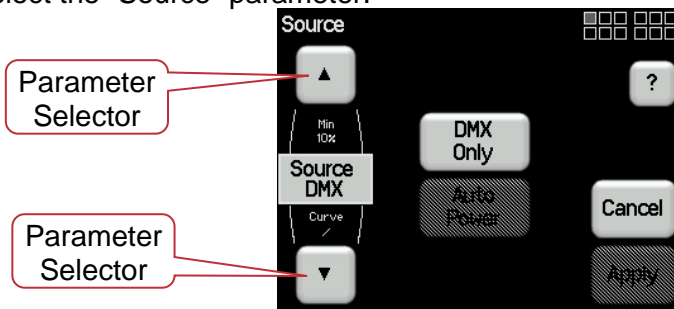

The control source for each GEN-VI channel can be either,

- **DMX Only.** Channels configured for “DMX Only” are controlled by the DMX signal from a lighting controller. Every DMX controlled channel can be set to be either a dimmer or a “Trupower” switch. When set to Trupower,
 - The channel will switch ON when the DMX signal exceeds 60%.
 - The channel will switch OFF when the DMX signal drops below 40%
 To select Dimmer or Trupower (switch) see section 5.7

- **Auto Power.** Channels configured for “Auto Power” will be *automatically* switched ON whenever any valid DMX signal is detected on the input to the GEN-VI. When DMX is no longer detected, these channels will remain on for a programmable “hold time”. See section 5.8.4 to set the hold time. Channels configured for “Auto Power” are used to provide switched power whenever the lighting controller is switched on and hence a DMX signal is detected on the input to the GEN-VI. Switched output provides direct power by utilising relays guaranteeing there are absolutely no electronics in the circuit to interfere with connected loads. “Auto Power” can only be selected if the channel is set to “TruPower”. See section 5.7 Global control of “Auto Power” can be enabled/disabled. See section 5.8.4

Select the required “Source” for the selected channel(s) then select **Apply**.

5.11 Colour Theme Menu

Selecting **Config, Colour Theme** provides menus for changing the colour of the display. The choices are:

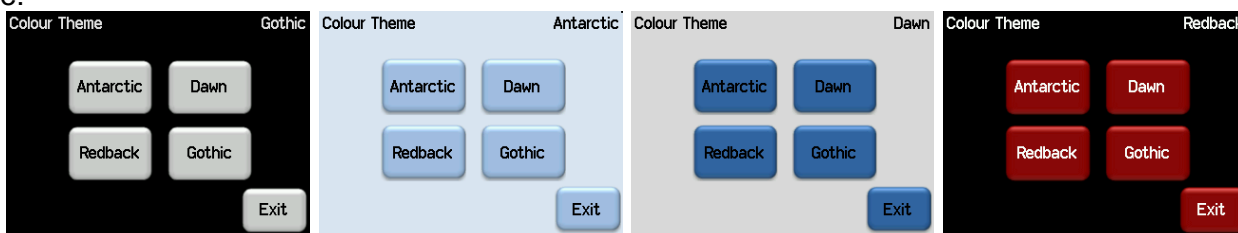

The default colour is “Gothic”.

5.12 System Menu

Selecting **Config, System** provides menus for the following functions,

- Code Upgrade
- Reset
- Service. (Factory use only)
- Fan Control
- Import Export

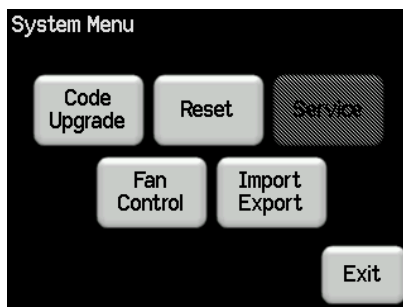

5.12.1 Code (Software) Upgrade

LSC Control Systems has a corporate policy of continuous improvement to its products. The GEN·VI dimmer software (firmware) is subject to this policy as new features are added and existing features improved. The software version of your GEN·VI dimmer can be checked from the “Dimmer Output” home page by pressing **Status, About**.

To upgrade your GEN·VI software, download the latest version from the LSC web site. www.lsccontrol.com.au

As of 2021, GEN·VI units are manufactured using two possible types of controller module. Both types perform the same functions but require their own version of the operating software. The downloaded software is a ZIP file containing both versions. Double click on the ZIP file to automatically extract the two files then save both files to a SD card. The controller module in the GEN·VI knows which filename to look for so only the correct code will be loaded and upgraded. Insert the SD card containing both files into the SD card socket on the GEN·VI. Press **Config, System, Code Upgrade**.

Hint: It is also possible to upgrade the software of later models of GEN VI (post 2021) via HOUSTON X. This is only possible on units running Bootloader v2.05 or later and fitted with a “Tm” controller module. In HOUSTON X, double click on the “App Version”. If it opens an update window, your GEN VI can be updated. Follow the on-screen instructions. If it does not open an update window then your GEN VI cannot be updated via HOUSTON X.

5.12.2 Reset

The GEN·VI provides two different types of reset function. Press **Config, System, Reset**. There are two options:

5.12.2.1 Restart

In the unlikely event that the GEN·VI fails to respond, the operating system may be restarted so that the software may initialise and recommence normal operation. Performing a restart will not affect any of the settings or memory.

5.12.2.2 Reset To Defaults

This will ERASE all memory from the GEN·VI (except the owner name and logo) and reset to defaults.

The default settings are;

ATTRIBUTE	DEFAULT SETTING
Min Level	0%
Max Level	100%
Fade Curve	Linear Curve
Control Source	DMX Only
Patch	1:1 starting at DMX slot 1

5.12.3 Fan Control

The internal fan in the GEN·VI is used to control its temperature. To set the fan control press **Config, System, Fan Control**.

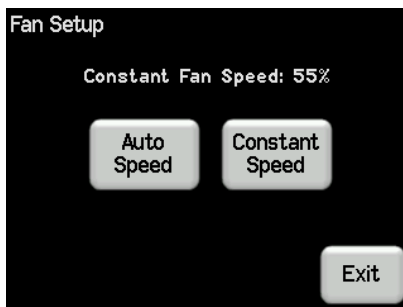

There are two choices of fan control,

- **Auto Speed.** The fan runs automatically when required. The higher the temperature the faster the fan runs
- **Constant Speed.** The fan runs constantly at a speed that you set from the touch screen. The speed range is from 0 to 100%. The letter “C” is displayed beside the fan symbol on the home page. If the temperature exceeds 65 Celsius the fan will run at full speed

5.12.4 Import Export

The configuration and/or dimmer curve of your GEN·VI dimmer can be exported to or imported from an SD card. This is useful for cloning the configuration to other units or for archiving. The SD card slot is located on the front panel. The configuration file name is fixed as “GNW_CFG.XML”. If you need to use multiple configurations than you should either use a separate SD card for each configuration or use a single SD card and manage your files on a computer.

To export or import a file press **Config, System, Import/Export**.

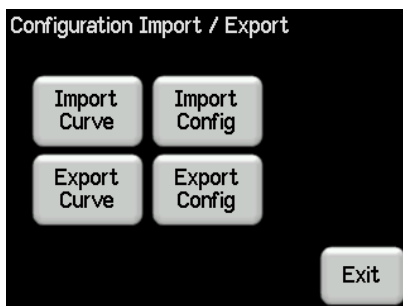

If there is no SD card in the dimmer or no file on the card then the import buttons are greyed out.

5.13 Lock / Unlock

To **lock** the touch screen of the GEN·VI and prevent unauthorised access press **Config**. If the screen is already locked, the Config button will be replaced by a padlock symbol. In either case, pressing that button will open the “Configuration Menu”.

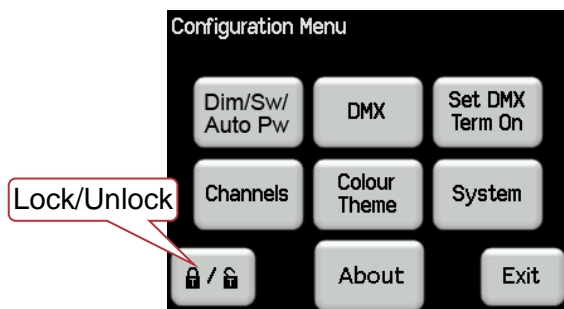

Pressing the “Padlock” symbol provides 2 levels of lock.

- User. Locks out the “Config”, “Riggers Control” and “DMX Address” menus
- Service. Locks out the “Service” menu

Note: The “Service” menu is used for factory setup and has no user functions.

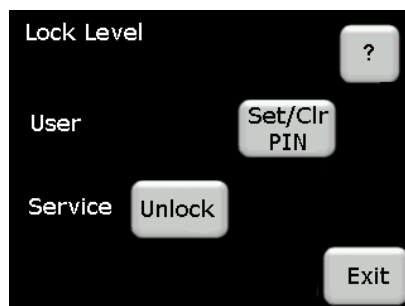

To set a PIN, press **Set/Clr PIN**. Enter a four-digit code. Entering 0000 clears the PIN.

If a PIN has been set, its “Lock” or “Unlock” button appears. Press **Lock** (or **Unlock**) to perform that task. You will be required to enter your PIN to unlock.

If a level has been locked, its “Set/Clr PIN” button is hidden.

6 Alarms and Troubleshooting

Warning. No user controls or user serviceable parts are located inside the GEN·VI Dimmer. Refer all servicing to suitably qualified personnel.

6.1 Maintenance

Ensure that the air vents are free from dust.
Check that the GEN·VI contains the latest software release.

6.2 Alarms

The Status bar at the bottom of the “Home Screens” indicates the following:



- **Auto Power** shows the status of the “Auto power” function that switches on selected channels when DMX is present. See section 5.8.4
Blue is active. Grey is not active
- **DMX Backup** is the “DMX loss” memory. See section 5.8.3
Blue is active. Grey is not active
- **P1, P2, P3** show the presence of the input power phases.
Green indicates power is present. Flashing red is not present
- **DMX** shows the presence of a DMX control signal.
Green is DMX present. Flashing Red is not present
- **16-bit** indicates that DMX control is using 16 bit resolution. See section 5.8.2
- **TERM** indicates that the DMX line is terminated by the GEN·VI dimmer. See section 5.9
- The GEN·VI has an internal cooling fan. The fan symbol is displayed when the fan is running. The fan speed can be controlled. See section 0
- The internal temperature of the GEN·VI is shown in degrees Celsius. The colour warns you if the temperature is too high.
 - At normal temperatures the display is green.
 - At 65C the display turns yellow.
 - At 75C the display turns red.
 - At 85C it flashes red.
 - At 90C the ALL OUTPUT is automatically switched OFF. A WARNING IS DISPLAYED ON ALL PAGES OF THE SCREEN.

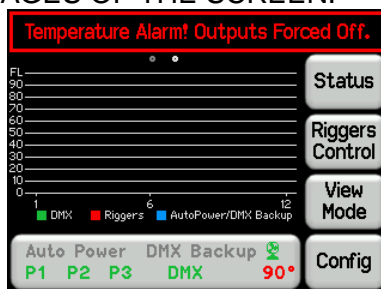

Either reduce the load or increase the cooling to reduce the temperature. If the fan has been set to a constant slow speed, either increase the speed or set it to “Automatic”. See section 0. Also check that the fan is operating and that the sides of the dimmer are not blocked.

When the temperature drops below 86 degrees the outputs are automatically switched back on.

Touching shows the legend for the display.....

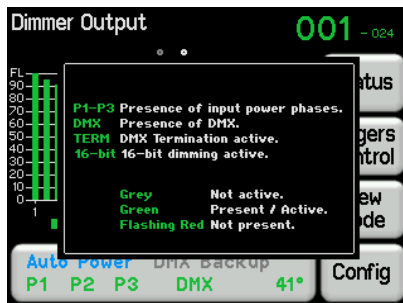

Touch anywhere within the legend window to close.

6.3 Trouble Shooting

If a channel is not working check the Circuit Breaker for that channel. If the Circuit Breaker has tripped (OFF), firstly try to determine the cause of the breaker tripping. It could be a blown lamp, a circuit overload or and earth leakage fault. Rectify the problem (replace the lamp or reduce the load) then restore the Circuit Breaker. If the Circuit Breaker continues to trip, refer the problem to a suitably qualified person.

If a channel will not turn on check the following,

- The fade curve is not set to “Tru Power”
- The Maximum level is not set too low
- Ensure that the load is plugged in
- If a custom dim curve is selected change to a S or L curve. If the channel now comes on, check the custom curve

If a channel will not turn off check the following,

- The Minimum level is set at 0%
- Riggers control is set to 0%
- Channel is not set to “Auto Power”

6.3.1 Rigger Test

You can test the operation of a dimmer channel from the “Riggers Control” on the LCD touch screen. See section 5.5

6.3.2 DMX Control

If the dimmer is working from the Riggers Control but not via DMX, check that the dimmer is patched to the correct DMX slot and correctly configured for DMX control.

You can check the DMX input signal from the touch screen. See section 5.8.6

7 HOUSTON X

HOUSTON X is LSC's monitoring and remote configuration tool that works with LSC products such as APS, GEN VI, MDR-DIN, LED-CV4, UNITOUR, UNITY and Mantra Mini. HOUSTON X can be downloaded from the LSC website, www.lsccontrol.com.au



HOUSTON X is the central overseer of your venue's equipment. The software runs on Windows computers. It gives you the absolute authority to interrogate, monitor and instantly change parameters of connected products.

Using HOUSTON X, you can quickly locate and isolate faults, monitor temperatures, phase loadings, change a channel from dimmer to power-switching mode (TruPower), upgrade software, all from one central location or remotely via the internet.

Some LSC products have additional functionality enabled when licensed to operate with HOUSTON X. The GEN VI dimmers have additional dimmer curves, as well as one-click mode setting to set the unit to TruPower and AutoPower in one operation. Four 12-channel GEN VI dimmers can also be configured as one 48-way unit.

8 DMX Explained

8.1 Overview

DMX512/1990-A is the industry standard for the transmission of digital control signals between lighting equipment. It utilises just a single pair of wires on which is transmitted the level information for the control of up to 512 DMX slots (addresses or channels). The information for each slot is sent sequentially. The level of slot 1 is transmitted, then the level of slot 2, then 3, etc. up to a maximum of 512 slots. This stream of data containing the levels for all 512 DMX slots is repeated a minimum (Generally) of 44 times per second. This provides sufficient updates of channel information for smooth fade transitions.

As the DMX512-A signal contains the level information for all slots, each piece of equipment needs to be able to read the level(s) of the slots(s) that apply only to that piece of equipment. To enable this, the GEN·VI dimmer has a “DMX Patch” menu that allows you to patch (connect) each DMX slot (address) from your lighting controller to a GEN·VI channel number or to multiple channel numbers.

When good quality data cables are used, DMX512 cable runs may be up to 1,000 metres in length. When several DMX feeds are required (to feed different locations), DMX512 splitters must be used. These provides multiple isolated DMX512 feeds. The GEN·VI uses a high impedance DMX input circuit allowing you to loop the DMX signal from one GEN·VI to the next. The last GEN·VI in the chain must have the “DMX Terminate switch” set to TERM to terminate the line.

Note: Do not use unscreened microphone or low speed data cables for DMX. This can cause problems in the DMX network. Make sure the cable conforms to the EIA485 cable requirements by providing the following specifications:

- Low capacitance
- One or more twisted pairs
- Foil and braid shielded
- Impedance of 85 -150 Ohms, nominally 120 Ohms
- 22AWG gauge for continuous lengths over 300 metres

8.2 Typical DMX Installations

In the following example, the DMX output signal from the lighting control desk is fed to the DMX connector of the first GEN·VI dimmer. The DMX cable is then looped to the following GEN·VI dimmers. The order of the daisy chaining is not important as each GEN·VI channel can be patched to any DMX slot number. The end of the DMX line is terminated to prevent the signal reflecting back up the line and causing possible errors.

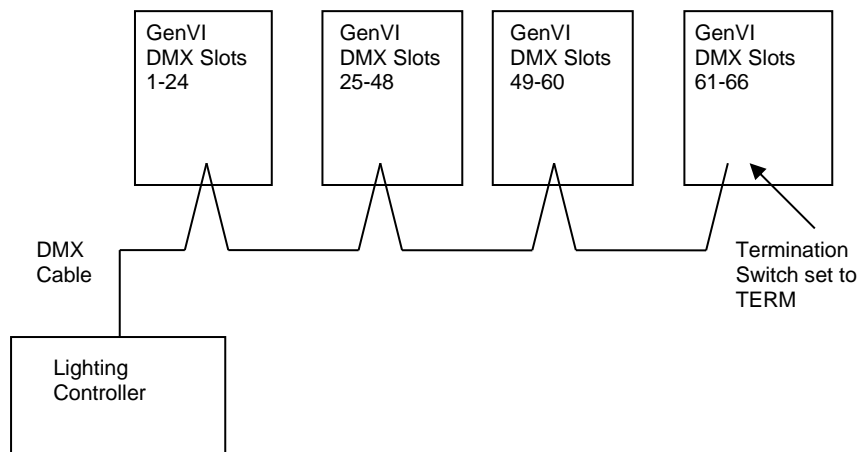

9 RDM

9.1 Overview

RDM stands for Remote Device Management. It is an “extension” to DMX.

Since the inception of DMX, it has always been a ‘one way’ control system. Data only ever flows in one direction, from the lighting controller outwards to whatever it may be connected to. The controller has no idea what it is connected to, or even if what it's connected to is working, switched on, or even there at all!

RDM changes all that allowing the equipment to answer back!

An RDM enabled moving light, for example, can tell you many useful things about its operation - the DMX address it is set to, the operating mode it is in, whether its pan or tilt is inverted and how many hours since the lamp was last changed.

But RDM can do more than that. It isn't limited to just reporting back, it can change things as well. As its name suggests, it can remotely manage your device.

RDM has been designed to work with existing DMX systems. It does this by interleaving its messages with the regular DMX signal over the same wires. There is no need to change any of your cables but because RDM messages now go in two directions, any in-line DMX processing you have needs to be changed for new RDM hardware. This will most commonly mean that DMX splitters and buffers will need to be upgraded to RDM capable devices.

To utilise RDM you will also need an RDM controller. Presently these are devices that plug in to the DMX line and talk the RDM language. They put the messages on to the DMX line, listen for any replies and display the results via an attached computer. The latest lighting consoles now also come with RDM controllers built in.

RDM also has the ability to read and report operating statistics and error conditions from any enabled equipment that supports it. This opens up the possibility of remotely monitoring the condition of your lighting rig and getting notice of failed equipment or even advanced notice of things that may be cause for concern. For example, a moving light that reports a very high bulkhead temperature may be suffering from a failed fan or clogged filter or a scroller that reports a high motor current may have a jammed scroll.

9.2 GEN-VI RDM

LSC's GEN-VI Dimmer range are RDM enabled products. This allows you to use RDM to change the DMX address of the dimmer and to interrogate the dimmer to find out its.

- Temperature
- Fan Speed
- Presence of input power phases 1-3
- Presence of DMX

The GEN-VI will also send out an over temperature alarm when the temperature reaches 90 Celsius.

10 PTFD Explained

10.1 Overview

PTFD stands for “Pulse Transformer Fired Dimmer”. It is a tried and proven piece of dimmer technology that is used in top quality dimmers including LSC’s GEN-VI range. However, many dimmer manufacturers now use low cost opto-isolator circuitry in their dimmers which can have some short comings as described below.

10.2 What is PTFD?

PTFD dimmers use a small “pulse transformer” to control their internal power control device, usually a triac or an SCR. We will use the Generic term “triac”. The triac is the part of the dimmer that actually controls the voltage coming out of the dimmer to the load. A 12 channel dimmer needed 12 transformers, one per channel. The transformer is used to provide isolation between the high voltage (100-240v) mains output and the low voltage (~12v) of the dimmer electronics. A pulsed signal is fed into the input of the transformer, and the output is connected to the input of the triac. The result is a dimmer that can control virtually any type of connected load. This includes inductive loads such as anything with a transformer in it. Examples are pin spots, 12v EVL dichroic lamp systems, reactive loads, discharge lamps and fluorescent lamps. In the 1980’s a new integrated circuit device became available known as an “opto-isolator” (also known as an optocoupler or a MOC). This device uses a LED and a phototransistor to provide the same level of high-low voltage isolation as a pulse transformer but at a far lower cost. Due to the lower cost and the fact that an IC is easier to work with than a transformer in manufacturing, the vast majority of dimmer manufacturers switched to this great new device.

10.3 Opto-isolated Problems

The opto-isolators used in low cost dimmers have one major disadvantage. They do not provide the power to drive the triac! Instead, the dimmer circuitry relies on the connected load to power the triac. Therefore, the opto-isolated dimmer’s performance is dependent on the load connected to it. In the case of a simple high power load such as a 1000 watt lamp this is not usually a problem. The problems occur when you try to control any of the following loads:

- Very low power circuits such as a 15w festoon lamp.
- Inductive loads, such as Pin spots or ELV 12v dichroic lamp systems.
- Transformers such as gobo rotator power supplies.
- Motors, such as mirror ball rotators.
- Motorised Disco Effects. These often contain a motor and a transformer.
- Reactive loads such as Intelligent lights, Discharge lamps and Fluorescent lamps

If the load is very small there is just not enough power to fire the triac. The result is that most opto-isolated dimmers require a minimum load of 100 watts in order to work. If the load is inductive or reactive then there is a problem with the voltage and current getting out of phase with each other which can cause a false trigger of the triac, which causes the lights to flicker or flash. If the load is both of the above such as a small transformer driving a gobo rotator or a 35 watt dichroic lamp then some opto-isolated dimmers will turn on but never turn off, so your light or gobo rotator keeps working at full power, even with the dimmer control at zero!

A PTFD dimmer rack does not have any of these problems. It simply dims the light as the operation of the triac is completely independent of the load.

10.4 Hard Firing

Some manufacturers use opto-isolators but employ a technique called “Hard Firing” to try and overcome the problems listed above. Hard firing involves sending a string of small pulses to the opto-isolator (just like we do with our PTFD’s), so that if/when the triac misfires or turns off from a lack of power, it will automatically re-trigger. Whilst this can help the situation the dimmer still cannot control certain loads. Some sales jargon will try to convince you that Hard Firing solves all the problems with opto-isolation. It does not!

10.5 The Proof

The best way to prove this is to demonstrate the problem. LSC staff carry a pin spot, a 12v desk lamp with transformer and a mirror ball motor with them when they do demonstrations. The LSC PTFD dimmers can control all of these devices without any problem. Almost all opto-isolated dimmers fail this demonstration completely. The mirror ball motor does not start or if it does it never stops. The pin spot flickers at low levels and the 12v desk light cannot be dimmed and stays on at full brightness as the dimmer channel is dimmed up and down. LSC GEN-VI dimmers are PTFD dimmers.

11 Specifications and Output Options

11.1 Rackmount GEN-VI

Rackmount Models	12 x 10A	12 x 16A Export Only	6 x 25A	3 x 63A
Control	3.2" colour LCD touchscreen Programmable stand-alone mode via easy-to-use menus DMX512 (1990) or DMX512-A (E1-11) input with RDM (E1-20) functionality on 5-pin XLR connectors Set individual channels to PTFD dimmer or TruPower switch mode Selectable fade curve, min and max levels per channel DMX snapshot scene for emergency backup on loss of signal			
Protection	12 channel x 10A RCBO breakers with 30mA trip per channel	12 channel x 16A RCBO breakers with 30mA trip per channel (Export only)	6 channel x 25A RCBO breakers with 30mA trip per channel	3 channel x 63A MCB and 30mA RCD per channel
Monitoring	Phases present, DMX, RDM, temperature and fan monitoring on main display Remote configuration and monitoring via RDM Remote configuration and monitoring via LSC's HOUSTON X software			
Power	Nominal 100-240V, 3-phase star, 50-60Hz Operating range typically 90-260V, 45-65Hz Hardwired models supplied with L1, L2, L3, N and E terminals for power connection. All other models as per below.			
	Supplied with 1.2m long H07 rubber 5 core x 6mm ² cable. (Export models supplied without connector, Australian models supplied with 32A 5-pin 3-phase plug fitted)	Supplied with 1.2m long H07 rubber 5 core x 10mm ² cable no connector supplied. (Export only. Not available in Australia)	Supplied with 1.2m long H07 rubber 5 core x 6mm ² cable. (Export models supplied without connector, Australian models supplied with 40A 5-pin 3-phase plug fitted)	Supplied with 1.2m long H07 rubber 5 core x 10mm ² cable. (Export models supplied without connector, Australian models supplied with 63A CeeForm 5-pin 3-phase plug fitted)
Mechanicals	483mm (w) x 300mm (d) x 132mm (h) – 3RU 19" rackmount weight: 19kg Full metal chassis with rear-screened polycarbonate labels Touchscreen, DMX input and RCBOs located on front panel Output connectors and power input cable located on rear panel			
Peace of mind	CE (European) and RCM (Australian) approved two-year warranty Designed and manufactured in Australia by LSC, an Australian-owned company with over 40 years' experience in developing world-first products			
Outputs	GEN12/10A 	GEN12/16T 	GEN6/25A 6 paired 3-pin	GEN3/63C 1 x 63A CeeForm per channel

	12 x 3-pin 10 Amp Australian sockets	Hardwired terminals	20Amp/15Amp Australian sockets	
	<p>GEN12/10S</p> <p>CEE7</p>	<p>GEN12/16S</p> <p>CEE7</p>	<p>GEN6/25T</p> <p>Hardwired terminals</p>	
	<p>GEN12/10T</p> <p>Hardwired terminals</p>	<p>GEN12/16W</p> <p>2 x 16-pin Wieland</p>		
	<p>GEN12/10W</p> <p>2 x 16-pin Wieland</p>	<p>GEN12/16X</p> <p>2 x 19-pin Socapex</p>		
	<p>GEN12/10X</p> <p>2 x 19-pin Socapex</p>			

11.2 Wallmount Gen VI

Wallmount Models	12 x 10A	6 x 25A
Control	3.2" colour LCD touchscreen Programmable stand-alone mode via easy-to-use menus DMX512 (1990) or DMX512-A (E1-11) input with RDM (E1-20) functionality on 5-pin XLR connectors Set individual channels to PTFD dimmer or TruPower switch mode Selectable fade curve, min and max levels per channel DMX snapshot scene for emergency backup on loss of signal	
Protection	12 channel x 10A RCBO breakers with 30mA trip per channel	6 channel x 25A RCBO breakers with 30mA trip per channel
Monitoring	Phases present, DMX, RDM, temperature and fan monitoring on main display Remote configuration and monitoring via RDM Remote configuration and monitoring via LSC's HOUSTON X software	
Power	Nominal 100-240V, 3-phase star, 50-60Hz Operating range typically 90-260V, 45-65Hz All models supplied with L1, L2, L3, N, and E terminals for power connection	
Mechanicals	490mm (w) x 270mm (d) x 250mm (h) weight: 16kg	

	<p>Full metal two-part hinged chassis with rear-screened polycarbonate labels</p> <p>Touchscreen, dimmer output connectors, RCBOs located on front panel</p> <p>DMX input located on right side panel</p> <p>Input power terminals housed internally, optional cable gland to allow flying tail to be connected</p>	
Peace of Mind	<p>CE (European) and RCM (Australian) approved</p> <p>two-year warranty</p> <p>Designed and manufactured in Australia by LSC, an Australian owned company with over 40 years' experience in developing world-first products</p>	
Outputs	<p>GVW12/10A</p> <p>12 x 3-pin 10 Amp Australian sockets</p>	<p>GVW6/25A</p> <p>6 paired 3-pin 20Amp/15Amp Australian sockets</p>
	<p>GVW12/10T</p> <p>Hardwired internal terminals</p>	<p>GVW6/25T</p> <p>Hardwired internal terminals</p>

11.3 Socapex Pinouts

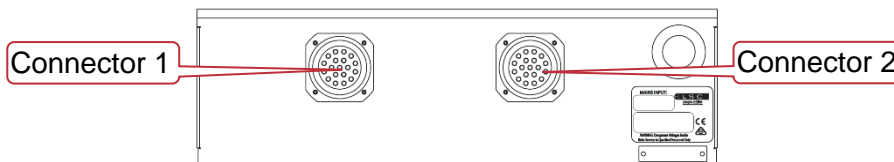

Connector #1	Function	Connector #2	Function
Pin 1	Chan 1 Active	Pin 1	Chan 7 Active
Pin 2	Chan 1 Neutral	Pin 2	Chan 7 Neutral
Pin 3	Chan 2 Active	Pin 3	Chan 8 Active
Pin 4	Chan 2 Neutral	Pin 4	Chan 8 Neutral
Pin 5	Chan 3 Active	Pin 5	Chan 9 Active
Pin 6	Chan 3 Neutral	Pin 6	Chan 9 Neutral
Pin 7	Chan 4 Active	Pin 7	Chan 10 Active
Pin 8	Chan 4 Neutral	Pin 8	Chan 10 Neutral
Pin 9	Chan 5 Active	Pin 9	Chan 11 Active
Pin 10	Chan 5 Neutral	Pin 10	Chan 11 Neutral
Pin 11	Chan 6 Active	Pin 11	Chan 12 Active
Pin 12	Chan 6 Neutral	Pin 12	Chan 12 Neutral
Pin 13	Earth	Pin 13	Earth
Pin 14	Earth	Pin 14	Earth
Pin 15	Earth	Pin 15	Earth
Pin 16	Earth	Pin 16	Earth
Pin 17	Earth	Pin 17	Earth
Pin 18	Earth	Pin 18	Earth
Pin 19	Earth	Pin 19	Earth

11.4 Harting/Wieland Pinouts

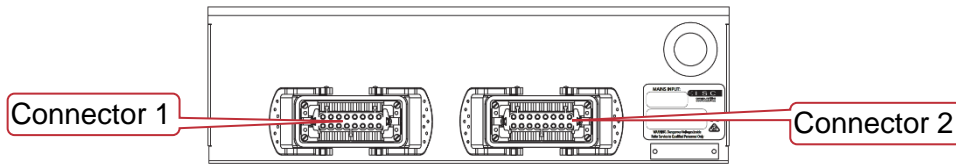

Connector 1	Function	Connector 2	Function
Pin 1	Chan 1 Active	Pin 1	Chan 7 Active
Pin 2	Chan 2 Active	Pin 2	Chan 8 Active
Pin 3	Chan 3 Active	Pin 3	Chan 9 Active
Pin 4	Chan 4 Active	Pin 4	Chan 10 Active
Pin 5	Chan 5 Active	Pin 5	Chan 11 Active
Pin 6	Chan 6 Active	Pin 6	Chan 12 Active
Pin 7	Not used	Pin 7	Not used
Pin 8	Not used	Pin 8	Not used
Pin 9	Chan 1 Neutral	Pin 9	Chan 7 Neutral
Pin 10	Chan 2 Neutral	Pin 10	Chan 8 Neutral
Pin 11	Chan 3 Neutral	Pin 11	Chan 9 Neutral
Pin 12	Chan 4 Neutral	Pin 12	Chan 10 Neutral
Pin 13	Chan 5 Neutral	Pin 13	Chan 11 Neutral
Pin 14	Chan 6 Neutral	Pin 14	Chan 12 Neutral
Pin 15	Not used	Pin 15	Not used
Pin 16	Not used	Pin 16	Not used

Note: Earth connection is via the clips on the side of the socket insert.

Note: This is the recommended wiring scheme for Harting/Wieland connectors. An alternative wiring scheme exists for these connectors and GEN·VI dimmers can be wired to the alternative scheme by special order. If you order the alternative wiring then the pin-outs are listed in a separate document that is included with your dimmer.

12 Feature History

The new features added to APS in each software release are listed below:

Release: v4.04 Date: 11-May-2023

- Reworked Lock screen user interface. It is now possible to set the Lock code independently of the Lock function.
- An About button has been added to the config menu screen. The about info can be accessed from this button, or via the existing status screen button.
- Software upgrades via RDM are now supported, but only on dimmers running Bootloader v2.05 or later (Ti only).
- The Zero Cross detection and Firing Engine have been updated to be even more reliable when running from generators or at extreme low/high voltages and frequency combinations (Ti only).
- Additional diagnostics information added to Service menu. Requires BootLoader v2.05 or later (Ti only).

Release: v4.03 Date: 14-Nov-2022

- Added support for RevB firing cards for Tm CPU card. The older NXP CPU cards are not compatible with the new RevB firing cards.
- The Owners Name function now permits numeric characters.
- The About menu now displays the CPU type and Firing card version.
- RDM Ident timeout added. If the user forgets to turn off Ident, the GENVI will do it automatically.

- RMD Ident now controls individual channels when a sub-device is selected.

Release: v4.02 Date: 03-Dec-2021

- Unified Code: Due to our policy of continual product improvements the GEN6 now has a new CPU card based on the Ti family of microprocessors. The new CPU card requires different software to the original NXP based cards. This is the first version of GENVI software that is available for both CPU variants and has all software features and GUI updates implemented in both versions. The unified code is based on our new v4 platform, hence the major version number jump from 1.xx to 4.xx. Some bug fixes apply to both CPU types and others are specific to one CPU type only, this is notated by the CPU type in brackets (e.g. Ti + NXP)
- The Dim/TruPower menu now allows selected channels to be changed to Dimming, Switch or Auto Power mode. The source is now automatically chosen as part of the selection (Ti + NXP)
- There is now a Cancel button in the TruPower configuration screen (Ti + NXP)
- The access levels for the menu system have been overhauled. The User and Owner Login levels are now redundant and have therefore been removed from the Login screen (Ti + NXP)

Release: v4.01 Date: 25-May-2021 (for Ti CPU cards only)

- The Logo and Owner name handling was improved. Messages changed to make user aware that they need to set name and logo before pushing LOCK. Once LOCK has been pushed, the name and logo cannot be changed without contacting the factory. This is for security reasons

All versions below are for NXP CPU only

Release: v1.21 Date: 22-July-2020

- The Logo and Owner name handling was improved. Messages changed to make user aware that they need to set name and logo before pushing LOCK. Once LOCK has been pushed, the name and logo cannot be changed without contacting the factory. This is for security reasons.

Release: v1.20 Date: 19-June-2020

- The RDM functionality has been extended to operate with HOUSTON X
- The owners name and logo security handling has been improved

Release: v1.10 Date: 07-Jun-2018

- The SD card reader has been revamped so that it can now read exFAT formatted cards
- The DMX update rate has been increased
- An upgrade file is now checked for and if present an upgrade button is presented. Previously the dimmer would reset regardless of whether there was a suitable file on the SD card or not

Release: v1.05 Date: 29-Apr-2015

- User confirmation now needed when changing channel configuration from TruPower to Curve
- Added quick TruPower/Dimming configuration page
- Support for 3-channel dimmer variant added
- Added 'Custom Logo' import from SD Card
- Added 'Custom Curve' import from SD Card

- Owner Text is now permanently locked (when set)
- Implemented Import / Export to SD Card
- Implemented RDM sub-devices
- Zero Cross Monitoring added to the Service page
- Zero Cross limits modification added to the Service page
- Zero Cross limits adjusted to include 60Hz waveform

Release: v1.03 Date: 01-Jul-2014

- Added support for 6-channel dimmer variant
- Non-Dim curve renamed to TruPower (Channel Configuration page)

Release: v1.00 Date: 13-Jan-2014

- First Public Release

13 Compliance Statements

The GEN VI dimmer from LSC Control Systems Pty Ltd meets all required CE (European), RCM (Australian) and UKCA (United Kingdom) standards.

CENELEC (European Committee for Electrotechnical Standardization).



Australian RCM (Regulatory Compliance Mark).



WEEE (*Waste Electrical and Electronic Equipment*).



The WEEE symbol indicates that the product should not be discarded as unsorted waste but must be sent to separate collection facilities for recovery and recycling.

For more information about how to recycle your LSC product, contact the dealer where you purchased the product or contact LSC via email at info@lsccontrol.com.au

You can also take any old electrical equipment to participating civic amenity sites (often known as 'household waste recycling centres') run by local councils. You can locate your closest participating recycling centre using the following links.

- AUSTRALIA <http://www.dropzone.org.au>.
- NEW ZEALAND <http://ewaste.org.nz/welcome/main>
- NORTH AMERICA <http://1800recycling.com>
- UK www.recycle-more.co.uk.

-END-