

DS

DS10
Manual 1.11 en

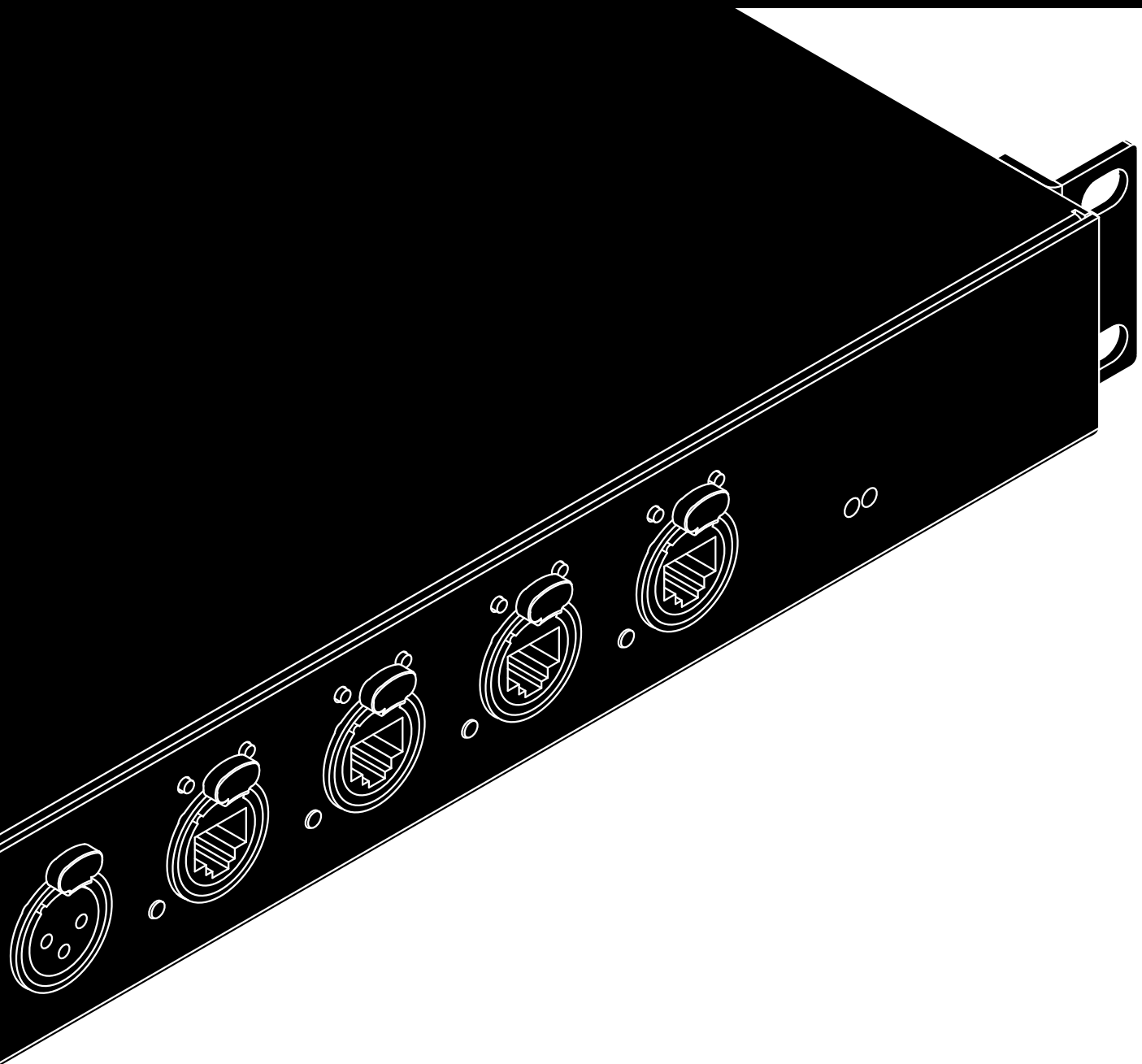

Notes on document version

All previous versions of this document are hereby no longer valid.

Version 1.11:

- Yamaha DM consoles added.

Refer to:

⇒ Chapter 7.2 "Setting Unit ID for Yamaha Consoles" on page 19.

- New DS10 firmware update procedure.

Refer to:

⇒ Chapter 7.3 "DS10 Firmware update" on page 19.

General information

DS10 Manual

Version: 1.11 en, 04/2024, D2027.EN .01

Copyright © 2024 by d&b audiotechnik GmbH & Co. KG; all rights reserved.

Keep this document with the product or in a safe place so that it is available for future reference.

We recommend you to regularly check the d&b website for the latest version of this document.

When reselling this product, hand over this document to the new owner.

If you supply d&b products, please draw the attention of your customers to this document. Enclose the relevant documents with the systems. If you require additional documents for this purpose, you can order them from d&b.

d&b audiotechnik GmbH & Co. KG
Eugen-Adolff-Str. 134, D-71522 Backnang, Germany
T +49-7191-9669-0, F +49-7191-95 00 00
docadmin@dbaudio.com, www.dbaudio.com

Explanation of graphical symbols



The lightning symbol within a triangle is intended to alert the user to the presence of uninsulated "dangerous voltages" within the unit's chassis that may be of sufficient magnitude to constitute a risk of electric shock to humans.



The exclamation point within a triangle is intended to alert the user to the presence of important operating and service instructions in the literature accompanying the product.

Before using this product, carefully read the applicable items of the following safety instructions.

1. Keep these instructions for future reference.
2. Read these instructions.
3. Heed all warnings.
4. Follow all instructions.
5. Keep water or other liquids away from the unit. Do not place liquid filled containers, for example beverages, on top of the unit.
6. Do not operate the unit while it is wet or standing in liquid.
7. Always operate the unit with the chassis ground wire connected to the electrical safety earth. Do not defeat the safety purpose of a grounding-type plug. A grounding-type plug has two blades and a third grounding prong. The third prong is provided for your safety. If the provided plug does not fit into your outlet, consult an electrician for replacement of the obsolete outlet.
8. Do not use this unit if the power cord is damaged or frayed. Protect the power cord from being walked upon or pinched, particularly at the plugs and the point where it exits from the apparatus.
9. The unit is intended for use in a 19" rack. Follow the mounting instructions. When a rack on wheels is used, exercise caution when moving the loaded rack to avoid injury from tipping over.
10. Unplug this apparatus during lightning storms or when unused for long periods of time.
11. Lay all cables connected to the unit carefully so that they cannot be crushed by vehicles or other equipment and that no one can either step on them or trip over them.
12. Refer all servicing to qualified service personnel. Servicing is required when the apparatus has been damaged in any way such as:
 - Power-supply cord or plug is damaged.
 - Liquid has been spilled into the unit.
 - An object has fallen into the unit.
 - The unit has been exposed to rain or moisture.
 - The unit does not operate normally.
 - The unit was dropped or the chassis is damaged.
 - Do not remove top or bottom covers. Removal of the covers will expose hazardous voltages. There are no user serviceable parts inside and removal may void the warranty.
13. Use the mains plug as the disconnecting device and keep it readily accessible. If the mains plug is not readily accessible due to mounting in a 19" rack, then the mains plug for the entire rack must be readily accessible.
14. An experienced user must always supervise the equipment, especially if inexperienced adults or minors are using the equipment.

1	DS10 Audio network bridge	5
1.1	Intended use.....	5
2	Scope of supply	6
3	Technical specifications	7
4	Startup	8
4.1	Overview.....	8
4.2	Rack mounting.....	9
4.3	Mains connection.....	9
4.4	Front panel.....	10
4.4.1	BYPASS/NETWORK.....	10
4.4.2	DIGITAL OUT 1 - 4.....	10
4.4.3	DIGITAL IN 1 - 4.....	10
4.4.4	ETH1 - ETH4.....	11
4.4.5	SYNC ERROR/SUBSCRIBED.....	12
4.5	Rear panel.....	12
4.5.1	ETH 5/MODE ETH 3.....	12
4.5.2	DIGITAL OUT 5 - 16.....	12
5	Rack connections	13
5.1	Use with d&b Touring rack I/O panel.....	13
6	Application examples	14
6.1	Redundant.....	15
6.2	FoH.....	16
6.3	Wireless control with external switches.....	17
6.4	Wireless control without external switches.....	18
7	References	19
7.1	Meta data.....	19
7.2	Setting Unit ID for Yamaha Consoles.....	19
7.3	DS10 Firmware update.....	19
8	Manufacturer's Declarations	20
8.1	EU declaration of conformity (CE symbol).....	20
8.2	WEEE Declaration (Disposal).....	20
8.3	Licenses and patents.....	20

1.1 Intended use

The d&b DS10 is a 16 output channel break-out box connecting the Dante audio network to the AES3 digital audio standard.

In addition, 4 x AES3 input channels are provided for use as a simple break-in box, e.g. at Front of House.

The DS10 is mainly intended for use within the d&b Touring rack assemblies.

Configuration and control of the device is performed using the Dante Controller software, which enables networkwide routing from one single software platform. The software is available for free download at www.audinate.com.

NOTICE!

The device complies with the electromagnetic compatibility requirements of EN 55103 (product family standard for audio, video, audio-visual and entertainment lighting control apparatus for professional use) for the environments E1 (residential), E2 (business and commercial), E3 (outdoor use in urban areas) and E4 (outdoor use in rural areas).

Acoustic interference and malfunctions may occur if the unit is operated in the immediate vicinity of high-frequency transmitters (e.g. wireless microphones, mobile phones, etc.). Damage to the device is unlikely, but cannot be excluded.

Before starting up the device, please verify the shipment for completeness and proper condition of the items.

If there is any sign of obvious damage to the unit and/or the power cord, do not operate the unit and contact your local dealer from whom you received it.

Note: For rack assembly instructions please refer to
⇒ Chapter 4.2 "Rack mounting" on page 9.

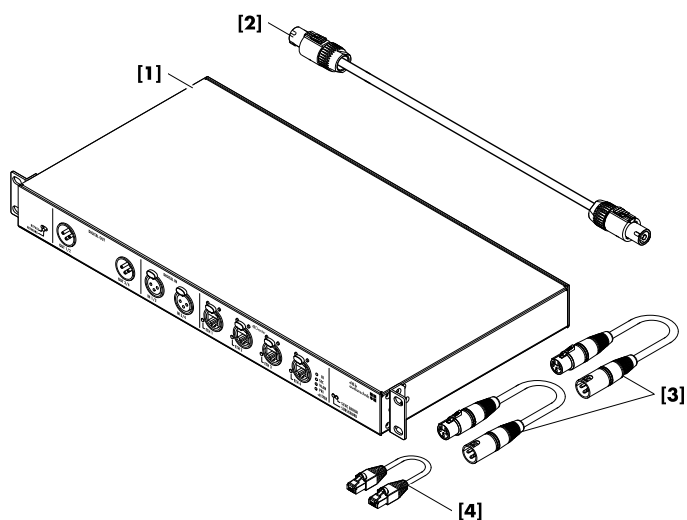
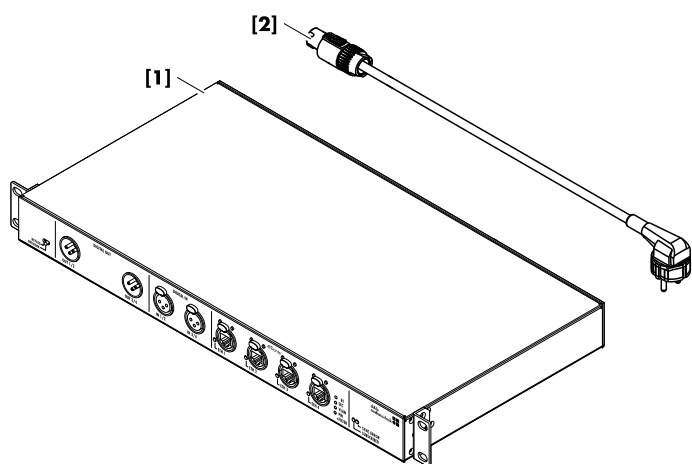

Z4010 DS10

Pos.	Qty.	d&b Code	Description
[1]	1	Z4010	d&b DS10 Audio network bridge.
Including:			
[2]	1	Z2610.xxx	Power cord (specific to country).
	1	D2027.EN .01	DS10 Manual.

Z5563 DS10 Rack upgrade kit

Pos.	Qty.	d&b Code	Description
[1]	1	Z4010	d&b DS10 Audio network bridge.
Including:			
[2]	1	Z2610.130	Power cord (powerCON/powerCON). Used to connect the device to auxiliary powerCON socket at the rear of the mains distributor.
[3]	2	E7500.024	AES/EBU XLR cable. Used to connect the digital outputs 1/2 and 3/4 to the digital inputs D1/2 and D3/4 of the I/O panel.
[4]	1	K6018.025	CAT5e patch cable. Used to connect the ETH 3 connector of the device to the ETH 1 connector of the I/O panel.
	1	D2027.EN .01	DS10 Manual.

Power supply

Mains connector powerCON®
 Rated mains voltage 100 to 240 V, 50 - 60 Hz
 Overvoltage protection Up to 400 VAC
 Power consumption 10 W (max)

Digital inputs

DIGITAL IN 4 channel (2 x AES3)
 3 pin XLR female
 Pin assignment 1 = GND, 2 = AES Signal, 3 = AES Signal
 Input impedance 110 ohms
 Sampling rate 32 - 192 kHz
 Synchronization Sample Rate Converter (SRC)

Digital outputs

DIGITAL OUT 16 channels (8 x AES3)
 3 pin XLR male
 Pin assignment 1 = GND, 2 = AES Signal, 3 = AES Signal
 Output impedance 110 ohms
 Sampling rate 48/ 96 kHz
 Synchronization Dante network

Network

Connectors etherCON®
 built-in 5-port Ethernet switch
 100/1000 Mbit

Controls and indicators

BYPASS/NETWORK Toggle switch
 Switch port modes/Audio loss RGB LEDs
 SYNC ERROR LED indicator red
 SUBSCRIBED (RX Subscription) LED indicator green

Operating conditions

Temperature range 0 °C ... 40 °C / 32 °F ... 104 °F
 Storage temperature -20 °C ... 70 °C / -4 °F ... 158 °F
 Humidity (rel.), long term average < 70%

Dimensions and weight

Height x width x depth 1 RU x 19" x 232 mm
 1 RU x 19" x 9.1"
 Weight 3.75 kg / 8.26 lb

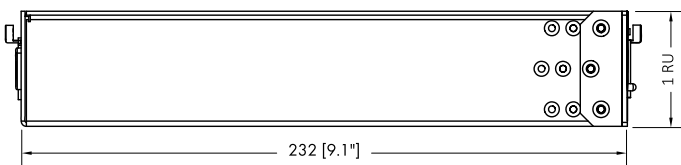

4.1 Overview

Front panel

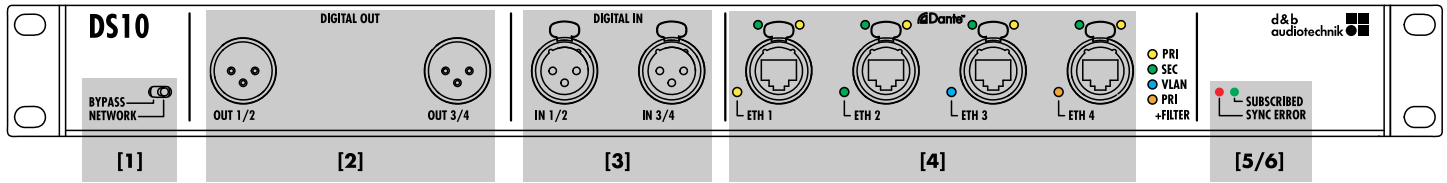

[1] BYPASS/NETWORK switch
Refer to ⇒ Chapter 4.4.1 "BYPASS/NETWORK" on page 10.

[2] XLR male digital outputs 1-4 (AES3).
Refer to ⇒ Chapter 4.4.2 "DIGITAL OUT 1 - 4" on page 10.

[3] XLR female digital inputs 1-4 (AES3) with Sample Rate Converters (SRCs)
Refer to ⇒ Chapter 4.4.3 "DIGITAL IN 1 - 4" on page 10.

[4] etherCON® Ethernet switch ports 1-4 with dedicated indicators for:

- Ethernet link/Activity indicator.
- Ethernet Gigabit indicator.
- Switch port mode indicator.

Refer to ⇒ Chapter 4.4.4 "ETH1 - ETH4" on page 11.

[5/6] SYNC ERROR and SUBSCRIBED indicators.
Refer to ⇒ Chapter 4.4.5 "SYNC ERROR/SUBSCRIBED" on page 12.

Rear panel

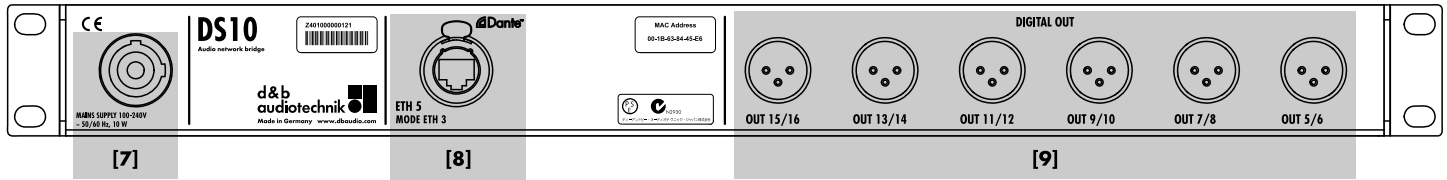

[7] powerCON® Mains connector socket.
Refer to ⇒ Chapter 4.3 "Mains connection" on page 9.

[8] etherCON® Ethernet switch port 5.
Refer to ⇒ Chapter 4.5.1 "ETH 5/MODE ETH 3" on page 12.

[9] XLR male digital outputs 5-16 (AES3).
Refer to ⇒ Chapter 4.5.2 "DIGITAL OUT 5 - 16" on page 12.

4.2 Rack mounting

The enclosure provides three different positions for the rack ears enabling different rack mounting options inside a d&b Touring rack assembly or any other rack assembly.

The corresponding positions and their intended purpose are shown in the table below:

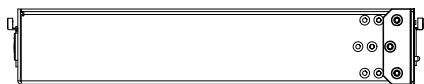

Flat:
Intended for any rack assembly.

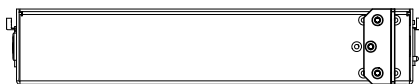

Pos. 1:
Used when mounted above the I/O panel.

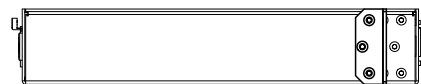

Pos. 2:
Used when mounted above the amplifier.

4.3 Mains connection



WARNING!
Potential risk of electric shock.

The device is a protective class 1 unit. A missing earth (ground) contact may cause dangerous voltages in the housing and controls and may lead to electric shock.

- Connect the unit to mains power supplies with protective earth only.
- If there is any sign of obvious damage to the power cord and/or mains connector, do not use the power cord and replace it before further use.
- Please ensure the mains connector is accessible at any time to disconnect the unit in case of malfunction or danger. If the mains plug is not readily accessible due to mounting in a 19" rack, then the mains plug for the entire rack must be readily accessible.
- Do not connect or disconnect the powerCON® mains connector under load or live.

Before connecting the device to mains voltage, check that the mains voltage and frequency correspond to the specifications on the rating label above the mains connector socket on the rear panel of the unit.

A powerCON® mains connector socket [7] is fitted on the rear panel and an appropriate power cord [2] is supplied.

CE

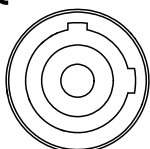

MAINS SUPPLY 100-240V
~ 50/60 Hz 10 W

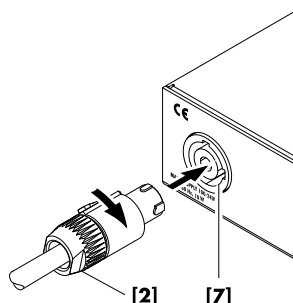

4.4 Front panel

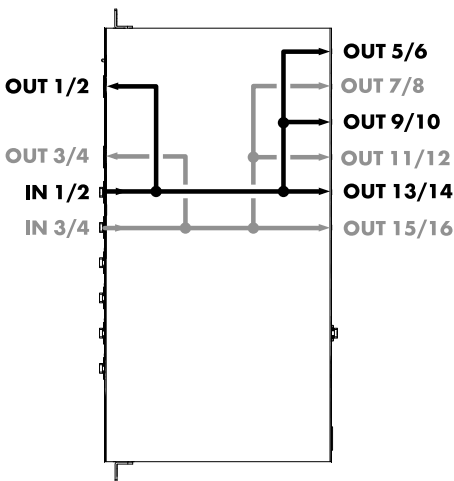
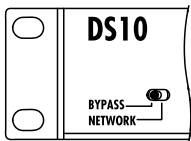
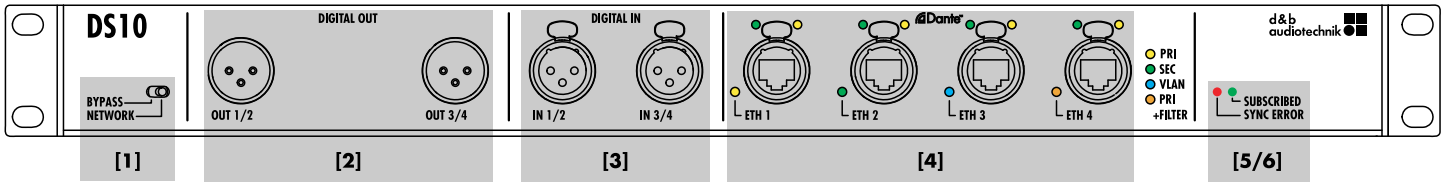

BYPASS/NETWORK switch
Bypass routing

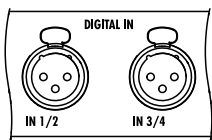
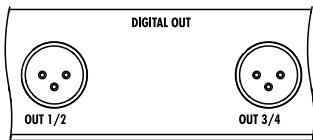

4.4.1 BYPASS/NETWORK

BYPASS/NETWORK switch

The BYPASS/NETWORK switch allows the use of the DS10 as an AES3 distribution amplifier. When set to “BYPASS” the digital inputs are routed (with negligible latency) to all outputs. That means Inputs 1-4 are routed simultaneously to outputs 1-4, 5-8, 9-12 and 13-16 as shown in the graphic opposite.

In “BYPASS” mode, the network switch is still fully operative (for example for use in control traffic), and the DS10 is shown in Dante Controller. However, no Dante routing is allowed from or into the device, and the device does not participate in the Dante master clock algorithm (i.e., it cannot act as Clock Master). The Network Switch Mode can still be configured from Dante Controller, and the corresponding port modes will be shown by the port LEDs.

When the switch is set to “NETWORK”, the DS10 operates as a normal Dante device.

The bypass switch can be operated while the device is working. When switching from “NETWORK” to “BYPASS”, the output channels are routed from the DS10 digital inputs as described above, and all devices on the Dante network that were receiving audio from the DS10 stop receiving immediately. When switching from “BYPASS” to “NETWORK”, these devices start receiving the audio from DS10 again, and the “RX Subscriptions” in the DS10 that were in place before switching to “BYPASS” are restored.

Note: When the DS10 is powered off while in bypass mode, the “RX Subscriptions” will not be re-established (all RX channels will be un-subscribed instead).

4.4.2 DIGITAL OUT 1 – 4

Two digital output connectors (OUT 1/2 and OUT 3/4) are provided and are intended to feed the AES signal to the inputs D1/2 and D3/4 of the I/O panel within a d&b Touring rack assembly.

4.4.3 DIGITAL IN 1 – 4

In addition, two digital input connectors (IN 1/2 and IN 3/4) are provided to allow the signal bridge to act as a break-in box with a maximum of four AES3 input channels per signal bridge.

Note: Sample Rate Converters (SRC) are used internally on both inputs.

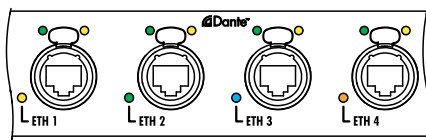

4.4.4 ETH1 - ETH4

The DS10 provides a 5-port Ethernet switch for different network topologies, redundancy and advanced functions.

Four connectors (ETH1 - ETH4) are provided on the front panel while a fifth port (ETH 5) is provided on the rear panel.

Network switch modes and functions

The device supports four different switch modes, which are intended for different applications and network topologies.

According to the mode, the Ethernet ports assume different roles, which are listed in the table below:

Note: The switch modes can be accessed from
Dante Controller ⇒ Device ⇒ Device View
⇒ Network Config.

Mode	ETH 1	ETH 2	ETH 3	ETH 4	ETH 5
Switched	Primary	Primary	Primary	Primary	Primary
Redundant + Multicast Filter	Primary	Secondary	Primary with Multicast Filter*	Primary with Multicast Filter*	Primary with Multicast Filter*
Redundant	Primary	Secondary	Primary	Secondary	Primary
Redundant + VLAN	Primary	Secondary	VLAN**	VLAN**	VLAN**

* Primary with Multicast Filter:

This port is connected to the Primary network, but Multicast traffic is filtered out. As Dante Synchronization is also Multicast-based, the port can not be used for connecting further Dante devices. This way, this port is particularly suited for connecting devices which do not need to send or receive Dante audio, such as applicable d&b amplifiers or WLAN Access Points for wireless control using d&b R1.

Note: Specifically, all IP Multicast packets are filtered out, except packets with Destination addresses 224.0.0.230 - 224.0.0.233 and 224.0.0.251.

** VLAN:

This port set is configured as a completely independent switch, forming a separate network. There is no logical connection between the VLAN ports and the Primary and Secondary ports. Use this configuration if you want to keep Dante audio separated from other Ethernet data (e.g. lighting protocols, control data ...).

Note: Dante Controller must be connected to the Primary and/or Secondary network.

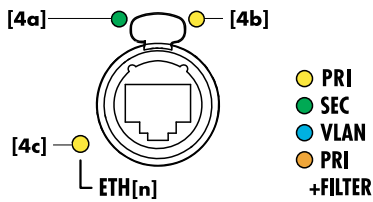

LED indicators

Each etherCON® connector provides the following LED indicators:

[4a] Ethernet link/Activity indicator (green).

[4b] Ethernet Gigabit indicator (yellow).

[4c] Switch port mode indicator (RGB-LED).

The color coding is as follows:

- **Yellow: PRI**mary.
- **Green: SEC**ondary.
- **Blue: VLAN**.
- **Orange: PRI**mary **+FILTER** (with Multicast filter).

In addition, the switch mode indicator on each port flashes when the signal bridge detects a subscribed audio channel is not available on that port, in this way allowing for faster network troubleshooting. For example, if the Secondary link of the mixing console is interrupted, the switch mode indicators of the ports configured as Secondary will flash.



4.4.5 SYNC ERROR/SUBSCRIBED

SYNC ERROR Illuminates red, when the signal bridge cannot synchronize to the Dante network.

In addition, when you click the IDENTIFY button in Dante Controller, the SYNC ERROR LED will flash rapidly for 2 seconds. This allows you to physically identify each DS10 when there is more than one device on the network (for more details, please refer to the Dante Controller User Guide).

SUBSCRIBED Illuminates green, when any of the signal bridge outputs has a configured subscription.

4.5 Rear panel

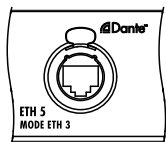
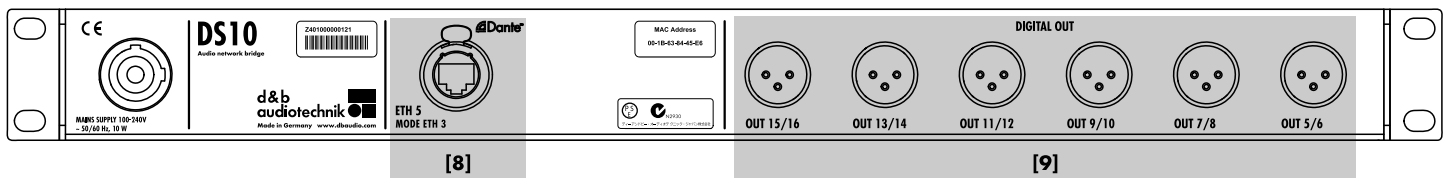

4.5.1 ETH 5/MODE ETH 3

A fifth Ethernet port is provided on the rear panel which is intended for the internal Ethernet wiring within a d&b Touring rack assembly.

Note: The ETH 5 port operates in the same port mode as ETH 3 (Refer to ⇒ "Network switch modes and functions" on page 11).

4.5.2 DIGITAL OUT 5 – 16

In addition, six digital output connectors are provided on the rear panel to allow further AES channels to be used if more than four AES channels are required.

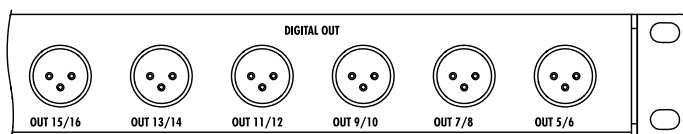

5.1 Use with d&b Touring rack I/O panel

**4 channels per rack
(Z5563 DS10 Rack upgrade kit)**

It is not necessary to re-cable the touring rack(s).

1. The DS10 is mounted above the I/O panel.
For this purpose, simply replace the rack drawer by the DS10.
2. Connect the two digital outputs at the front of the DS10 to the digital inputs D1/2 and D3/4 of the I/O panel using the two enclosed XLR cables [3].
3. Connect the ETH 3 port of the DS10 to the ETH 1 port of the I/O panel in order to bridge the R1 control for the amplifiers over the Dante network using the enclosed RJ45 patch cable [4].

Note: Connect only one of the Ethernet ports on the I/O panel to the DS10. Otherwise an Ethernet ring is built, causing a packet storm ⇒ Network no longer accessible.

4. On the rear, connect the power cord [2] (powerCON/ powerCON) to the auxiliary powerCON socket of the mains distributor.

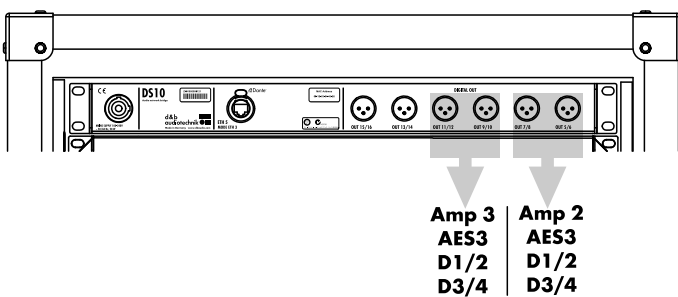
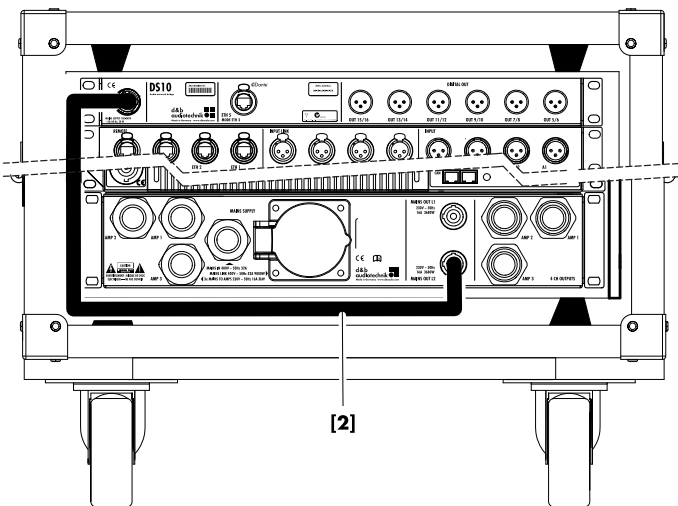
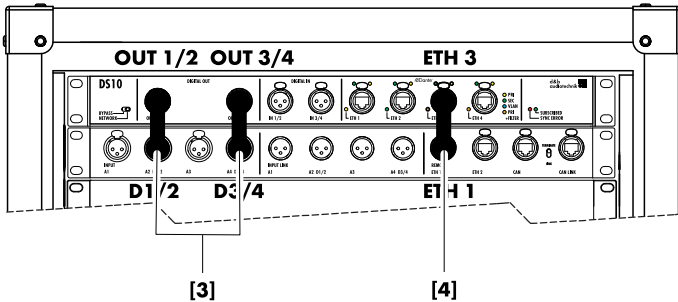

**12 channels per rack
(Z5339 Multichannel Extension Cable)**

For this purpose, the d&b Z5339 Multichannel Extension Cable is available (to be ordered separately).

If more than four channels per rack are required, the digital output connectors at the rear can be used to feed the lower two amplifiers in the rack separately, for a total of 12 different channels from the Dante network.

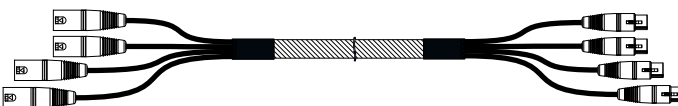

d&b Z5339 Multichannel Extension Cable

In the following sections some example network topologies are described, each with the recommended DS10 switch modes.

These examples are for illustration purposes only, and do not aim to cover every possible application, nor describe comprehensive PA Systems.

It is not possible to provide an exhaustive list of all possible applications and combinations, but please feel free to contact us with your application requirements.

Note: A detailed description on Dante and Networking best practices is given in the technical information TI 317 (d&b code D5317) which can be downloaded from the d&b website at www.dbaudio.com.

6.1 Redundant

Switch mode configuration:

"Redundant"

To ensure increased reliability, two parallel Dante networks can be built. If one fails, audio will continue to pass without any kind of interruption on the other network.

Note: For remote control, applicable d&b amplifiers will normally be connected to the Primary network.

Redundant control of applicable d&b amplifiers is not supported.

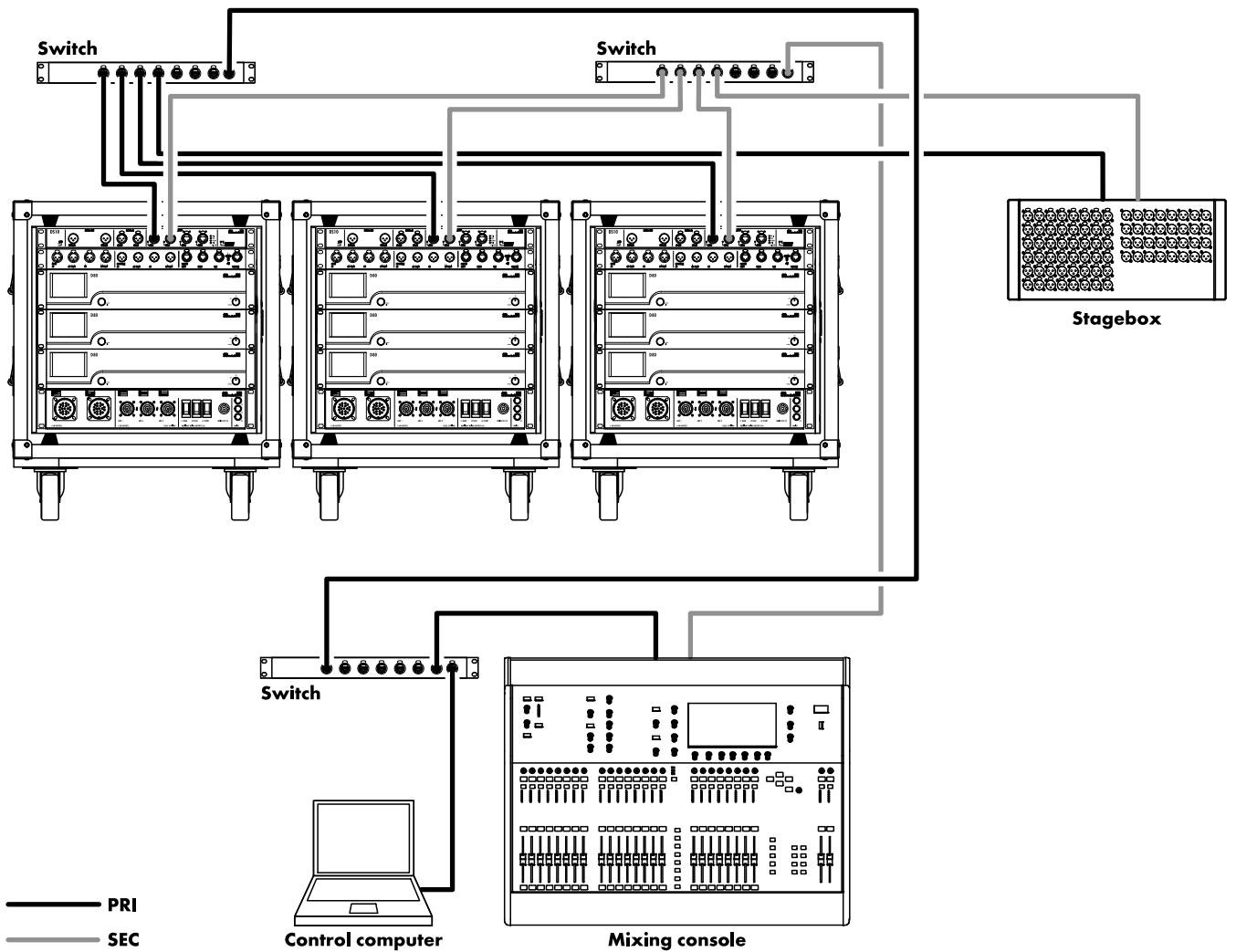

6.2 FoH

Switch mode configuration:

"Switched"

The DS10 can also be used as a break-in box with a maximum of four AES3 Input channels per DS10 (additional DS10 can be used, if more channels are required at the FoH). A star wired configuration is shown below, but the same principles apply to a Redundant configuration.

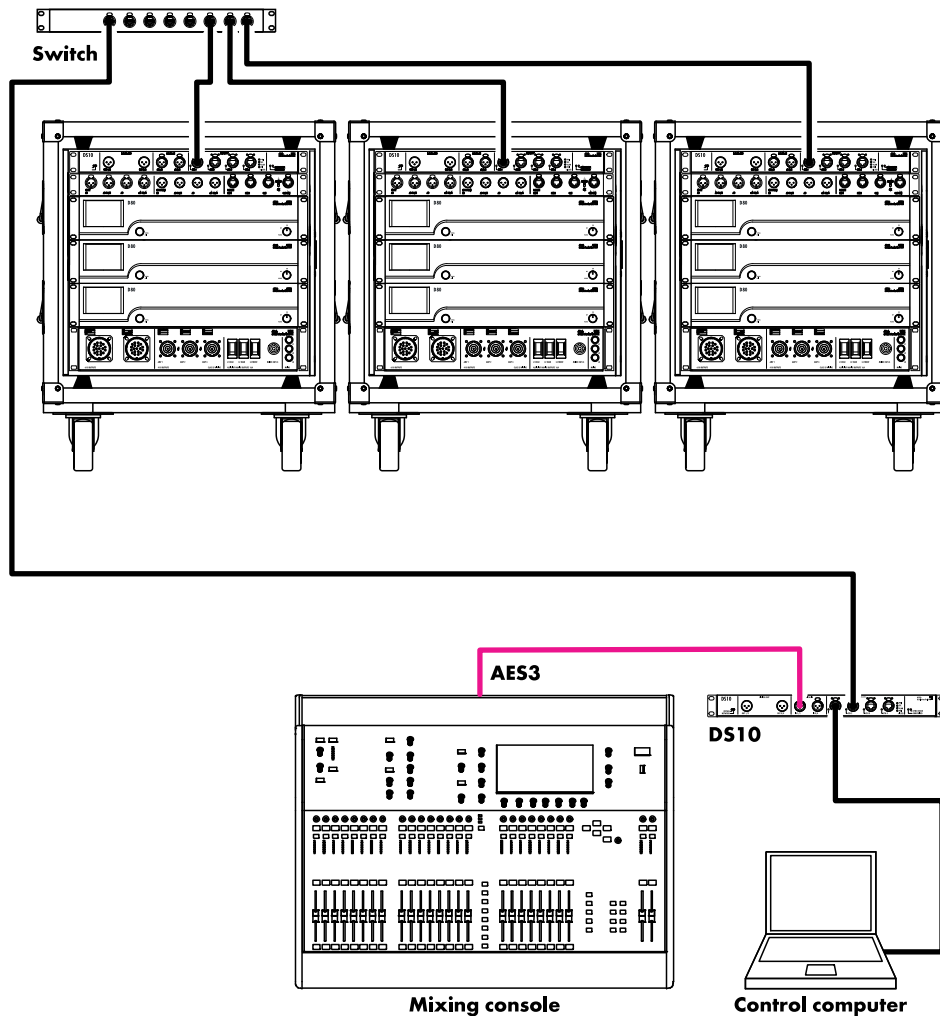

6.3 Wireless control with external switches

Switch mode configuration:

"Switched"

Dante multicast traffic can easily saturate a wireless link. In order to prevent this, an external switch with IGMP Snooping may be used. The switch only routes multicast audio to the Dante nodes that have requested it, and not to the port to which the Wireless Access Point is attached.

Note: Some switches provide the option to filter all multicast traffic on individual ports. However, this can also filter out some desired multicast traffic, such as mDNS (aka Bonjour), which is required by R1 V2 in order to detect applicable d&b amplifiers on the network.

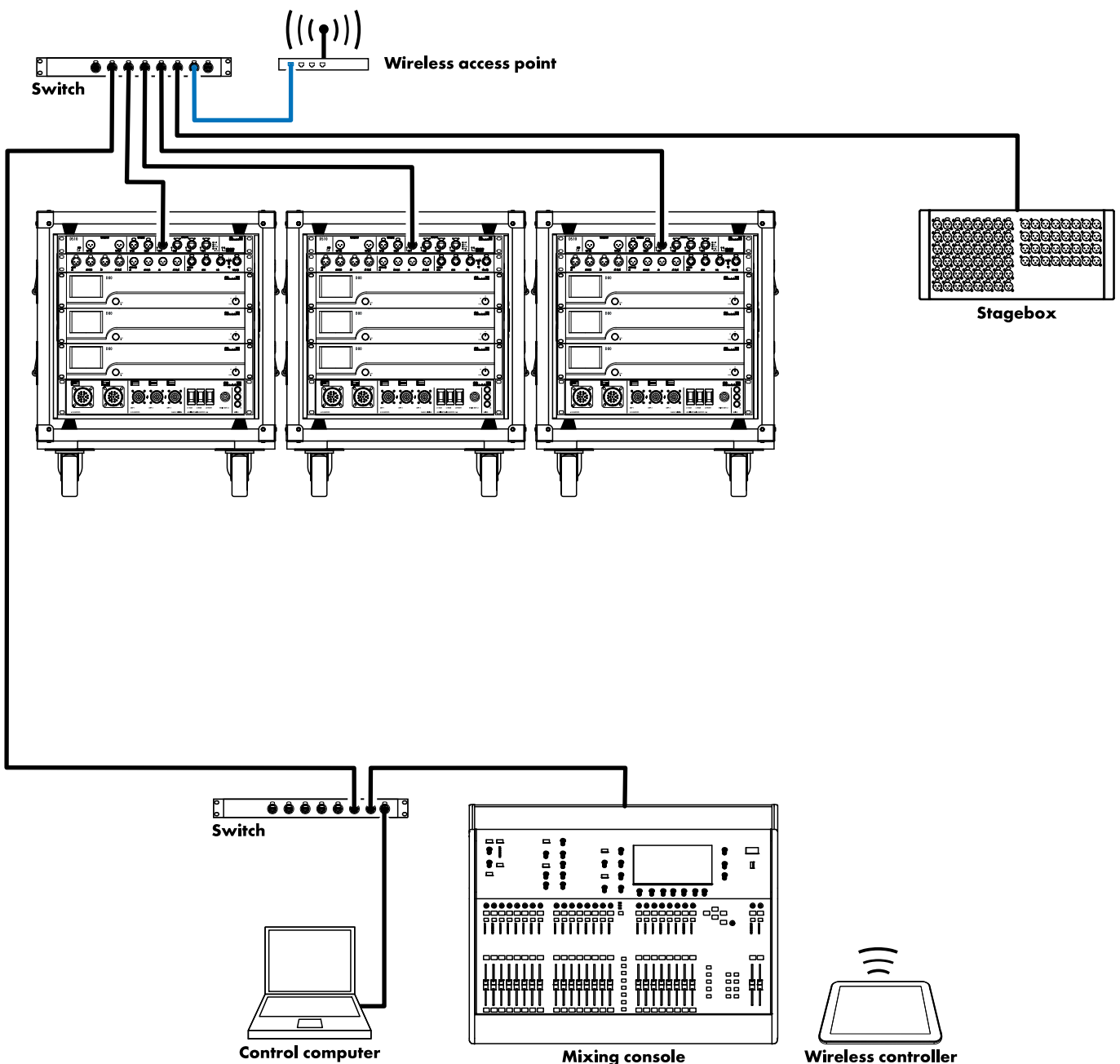

6.4 Wireless control without external switches

The DS10 provides a dedicated switch configuration to filter out multicast audio, but allows multicast control to pass through. This enables wireless control without the need for external switches with IGMP Snooping.

Switch mode configuration:

The DS10 in the left and central Touring racks are set to "Redundant" and the DS10 in the right Touring rack is set to "Redundant + Multicast Filter" mode.

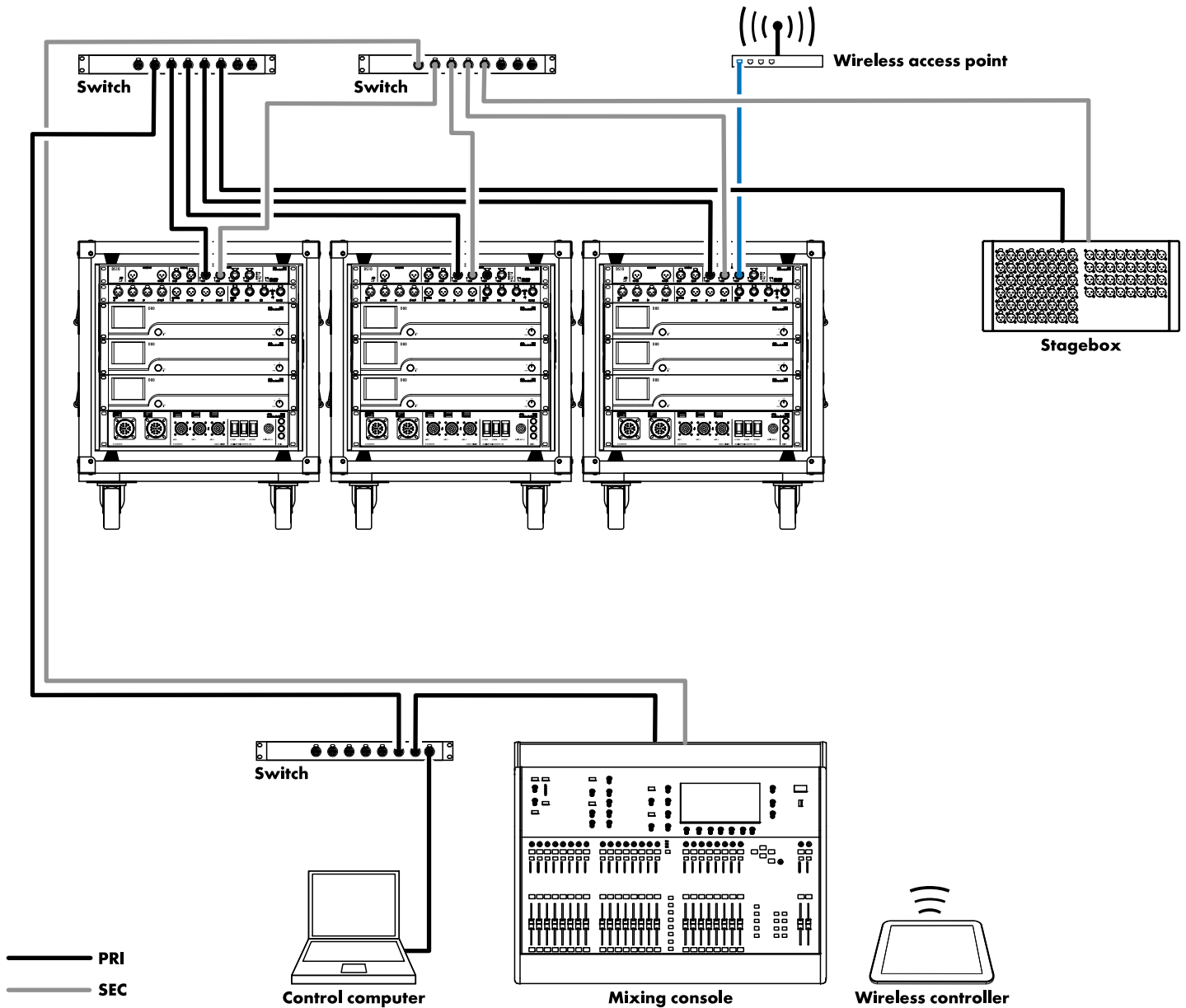

7.1 Meta data

The DS10 sends meta data (Dante channel labels, cabling information...) via the AES3 outputs alongside the digital audio samples, using the AES3 User bits.

These meta data can be read out by the d&b four channel amplifiers (DS labels).

In addition, these meta data can also be displayed in R1 via the d&b Remote network.

For more information, please refer to the respective amplifier manuals and/or the R1 Help system.

7.2 Setting Unit ID for Yamaha Consoles

Yamaha CL/QL consoles (Firmware version 4.10 or higher) and PM consoles (Firmware version 2.02 or higher) and DM consoles support the mounting of a DS10 directly from the console.

NOTICE!

For use with Yamaha DM consoles, DS10 firmware 2.0.4.1 (= Product Version 1.0.1) or higher must be installed.

For this purpose, a Unit ID must be defined for the DS10. This is done by changing the DS10 Device name using Dante Controller.

The Device name has to adhere to the following format:

Y[nnn] - [User Defined Name]

where [nnn] is the desired Unit ID.

Example

Device name: Y002-DS10-StageLeft
has a Unit ID of 002.

For further information, please also refer to the respective Yamaha Console User Manuals.

7.3 DS10 Firmware update

A DS10 Firmware update is performed using the «Dante Updater» which is included within the «Dante Controller» software.

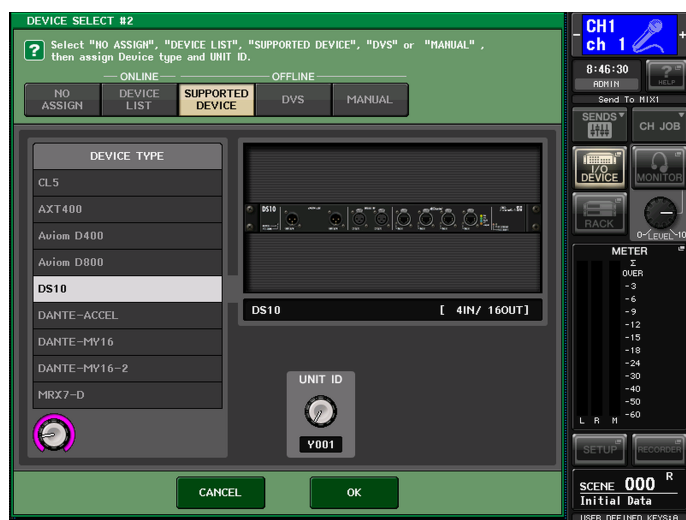

Example screen CL/QL consoles



8.1 EU declaration of conformity (CE symbol)

This declaration applies to:

d&b Z4010 DS10 Audio network bridge

by d&b audiotechnik GmbH & Co. KG.

All product variants are included, provided they correspond to the original technical version and have not been subject to any later design or electromechanical modifications.

We herewith declare that said products are in conformity with the provisions of the respective EC directives including all applicable amendments.

A detailed declaration is available on request and can be ordered from d&b or downloaded from the d&b website at www.dbaudio.com.



8.2 WEEE Declaration (Disposal)

Electrical and electronic equipment must be disposed of separately from normal waste at the end of its operational lifetime.

Please dispose of this product according to the respective national regulations or contractual agreements. If there are any further questions concerning the disposal of this product, please contact d&b audiotechnik.

WEEE-Reg. -Nr. DE: 13421928

8.3 Licenses and patents

The DS10 includes licenses from Audinate Pty Ltd under U.S. patent number(s) 7747725, 8005939, 7978696, 8171152 and other patents issued, see www.audinate.com/patents.

