

USERMANUAL

P·6 Standard

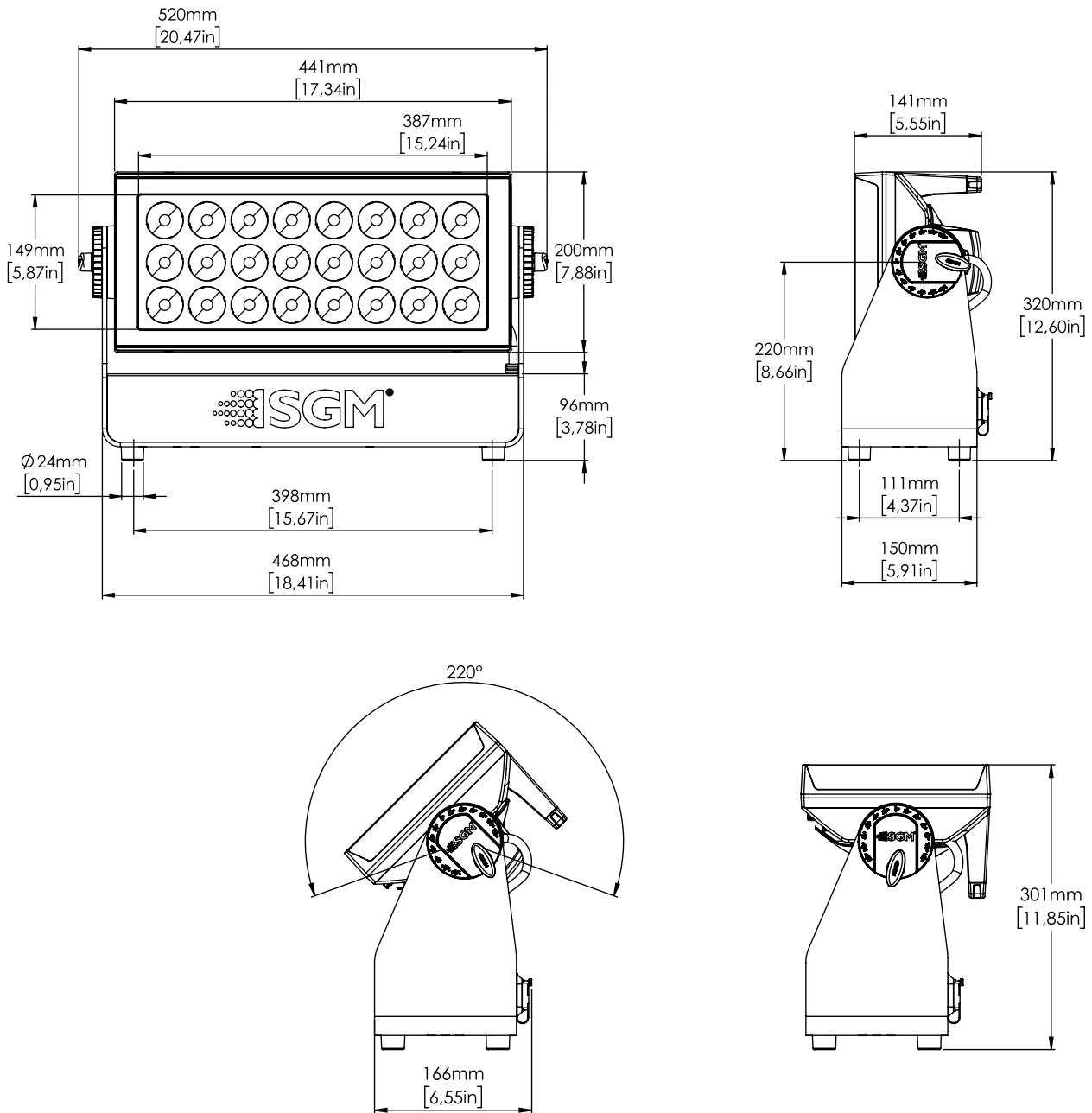

P-6 STANDARD DIMENSIONS



All dimensions in millimeters and inches. Drawing not to scale

This manual covers installation, use, and maintenance of the P-6 SGM Series. A digital version is available at www.sgmlight.com or upon request via support@sgmlight.com. The information in this document is subject to change without notice. SGM and all affiliated companies disclaim liability for any injury, damage, direct or indirect loss, consequential or economic loss, or any other loss occasioned by the use of, inability to use, or reliance on the information contained in this manual. The SGM logo, the SGM name, and all other trademarks in this document pertaining to SGM services or SGM products are trademarks owned or licensed by SGM, its affiliates, and subsidiaries. This edition applies to firmware version 4.02 or later.

English edition © 2024 SGM Lighting ApS.

2	P-6 STANDARD DIMENSIONS
5	SAFETY INFORMATION
6	BEFORE INSTALLING THIS PRODUCT
7	INSTALLATION P-6 STANDARD
7	Identification and terminology
8	Unpacking
8	Application considerations
8	Transport handling
8	Rigging
9	Rigging process using SGM Omega brackets
10	Tilt lock
10	Power requirements
11	Connecting power
11	Connecting data
11	Connecting a wireless transmitter
11	Signal priority
12	USER INTERFACE
12	Using the display panel
12	Shortcuts
13	DISPLAY
13	Operational mode (A)
13	DMX Address (B)
13	External data protocol (C)
13	Next available address (D)
13	External data indicator (E)
13	Information panel (F)
13	Warning Indicator
14	CONFIGURING THE DEVICE FOR DMX CONTROL
14	About DMX
14	DMX Start address
14	Set/edit DMX address
14	Setting the DMX mode
14	DMX charts
15	SETTING A STATIC COLOR MANUALLY
15	USING STANDALONE OPERATION
16	FIXTURE PROPERTIES
16	Factory default
16	LED Engine
16	Individual fixture settings
17	CONTROL MENU
19	RDM
19	Supported RDM functions
19	Sensors
19	PID COMMANDS

CONTENT

20 ACCESSORIES

20 Barndoors

21 Filter frames

21 MAINTENANCE

21 SGM Vacuum Test kit

21 USB - XLR Uploader cable

22 Firmware Updates

22 Cleaning

23 TROUBLESHOOTING

23 FIXTURES AND ACCESSORIES

23 Ordering information

23 Accessories

24 SUPPORT HOTLINE

24 APPROVALS AND CERTIFICATIONS

25 USER NOTES



WARNING! READ THE FOLLOWING SAFETY PRECAUTIONS CAREFULLY BEFORE UNPACKING, INSTALLING, POWERING OR OPERATING THE DEVICE.



SGM fixtures are intended for professional use only. They are not suitable for household use.

Les fixtures SGM sont impropres à l'usage domestique. Uniquement à usage professionnel.

This product must be installed in accordance with the applicable installation code by a person familiar with the construction and operation of the product and the hazards involved.

Ce produit doit être installé selon le code d'installation pertinent, par une personne qui connaît bien le produit et son fonctionnement ainsi que les risques inhérents.



DANGER! RISK OF ELECTRIC SHOCK DO NOT OPEN THE DEVICE!

- Always power off/unplug the fixture before removing covers or dismantling the product.
- Ensure that the mains power is cut off when wiring the device to the AC mains supply.
- Ensure that the device is electrically connected to earth (ground).
- Do not apply power if the device or mains cable is in any way damaged.
- Do not immerse the fixture in water or liquid.



WARNING! TAKE MEASURES TO PREVENT BURNS AND FIRE!

- Install in a location that prevents accidental contact with the device.
- Install only in a well-ventilated space.
- Install at least 0.3 m (12 in.) away from objects to be illuminated.
- Install only in accordance with applicable building codes.
- Ensure a minimum clearance of 0.3 m (12 in.) around the cooling fans.
- Do not paint, cover, or modify the device, and do not filter or mask the light.
- Keep all flammable materials well away from the device.

ALLOW THE DEVICE TO COOL FOR 15 MINUTES AFTER OPERATION BEFORE TOUCHING IT
CAUTION: EXTERIOR SURFACE TEMPERATURE AFTER 5 MIN. OPERATION = 47°C (117°F).
STEADY STATE = 61°C (142°F).



WARNING! TAKE MEASURES TO PREVENT PERSONAL INJURY. DO NOT LOOK DIRECTLY AT THE LIGHT SOURCE FROM CLOSE RANGE.

- Take precautions when working at height to prevent injury due to falls.
- For a temporary installation with clamps, ensure that the quarter-turn fasteners are turned fully and secured with a suitable safety cable. The standard safety wire cable must be approved for a safe working load (SWL) of 10 times the weight of the fixture, made of a grade AISI 316 steel, and it must have a minimum gauge of 4 mm.
- For elevated installations, secure the fixture with suitable safety cables, and always comply with relevant load dimensioning, safety standards, and requirements.

BEFORE INSTALLING THIS PRODUCT

Please visit the SGM official website at www.sgmlight.com for the latest version of this user manual/ safety information leaflet. Due to continuous improvements, the instructions may change without notice. SGM always recommends the latest available firmware version from www.sgmlight.com.



EXTERNAL CLEANING AND VISUAL INSPECTION OF THE FIXTURE

All users of SGM luminaires should regularly clean those parts of the luminaire directly exposed to the elements, such as the external housing and front lenses. Additionally, all owners of SGM luminaires must periodically check the external housing of the luminaire for structural breaks, components in bad shape, cracked lenses, or loose screws. To ensure proper operation, but also to prevent the risk of potential accidents, do not use the luminaire if the lens, housing, or power cables are damaged. If parts of the luminaire appear to be missing, cease use immediately and contact SGM support.



WIRING AND CONDUIT/ CONTAINMENT

SGM luminaires supplied with power and data cable leads are not intended for installation in permanently installed conduit or containment. When installing luminaires in a permanent installation, ensure cable leads are installed as a service loop to an appropriately rated junction box using suitable cable strain reliefs / glands. All installed luminaires must be securely mounted and service loop appropriately protected for installation location. All electrical wiring and connections should be completed by a qualified electrician.



SAFETY PRECAUTIONS

When using electrical equipment, basic safety precautions should always be followed including the following:

- Do not mount near gas or electric heaters.
- Permanently installed equipment should be mounted in locations and at heights where it will not readily be subjected to tampering by unauthorized personnel.
- The use of accessory equipment not recommended by the manufacturer may cause an unsafe condition.
- Do not use this equipment for other than intended use.
- Refer service to qualified personnel or authorized service centers.
- Do not look directly into the beam for long periods of time, when the fixture is on.
- The luminaire shall, under no circumstance, be covered with insulating material of any kind.

READ AND FOLLOW ALL SAFETY INSTRUCTIONS.

IDENTIFICATION AND TERMINOLOGY

- A: 24 x RGBW LEDs
- B: Tilt lock
- C: Cooling fans
- D: Control panel
- E: OLED Display
- F: Rubber feet
- G: GORE-TEX membrane
- H: Power In/Out
- I: DMX In/Out
- J: Handle
- K: Barndoors attachment points
- L: Safety wire attachment point
- M: Holes for Omega bracket / M-10 screws (x6)

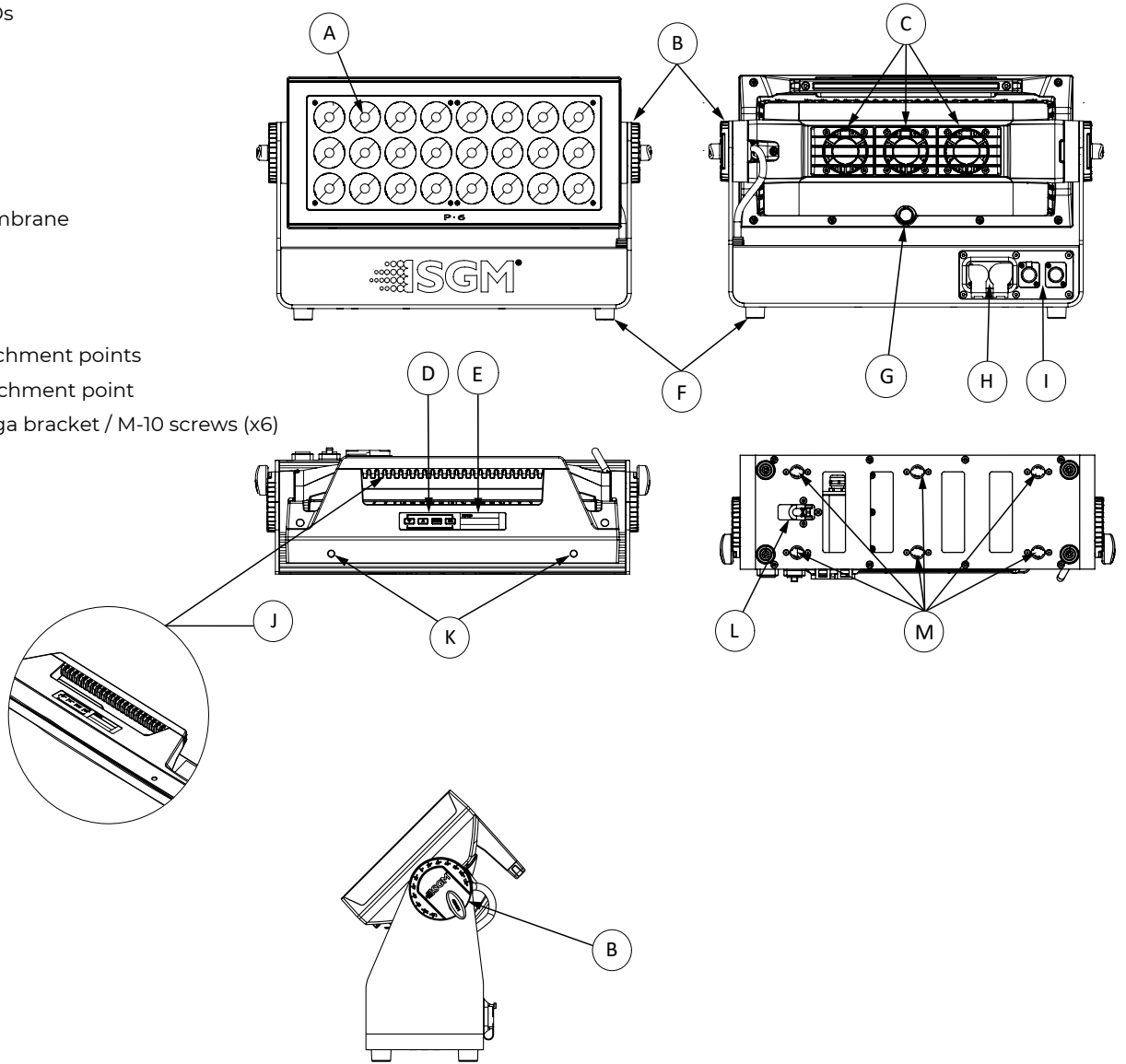

Illustrations might vary from received products. This is subject to change without notice.

UNPACKING

Unpack the device and inspect it to ensure that it has not been damaged during transport.

The fixture is shipped with:

- 2 x Omega bracket with 1/4-turn fasteners (standard only).
- 1 x Power cable with IP connector, 2 m./ 78 in
- Safety information leaflet.

APPLICATION CONSIDERATIONS

The standard fixture is IP66-rated and is designed for both indoor and outdoor events. This means that it is protected from:

- Dust, to the degree that dust cannot enter the fixture in sufficient quantities as to interfere with its operation.
- Lower pressure water jets from any direction.

When using standard fixtures outdoors or in wet locations, ensure that:

- The DMX connection out of the last fixture in a chain is properly sealed, in accordance with the ingress protection (IP) requirements.
- The DMX out of the last fixture is terminated with a 120 Ohm resistor between pin 2 and 3 (as per RS485 standards).

When selecting a location for the device, ensure that:

- It is situated away from public thoroughfares and protected from contact with people.
- It has adequate ventilation.
- It is not immersed or submerged in water.

TRANSPORT HANDLING

Always use the supplied packaging or suitable flight case for transportation and storage. Never carry the fixture by connected cables or wires.

RIGGING

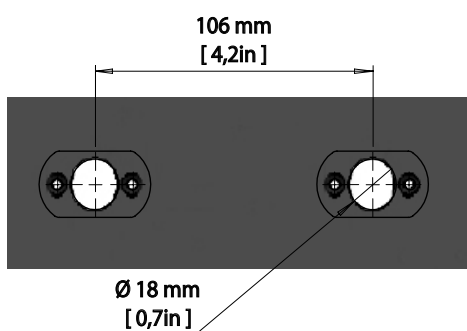

Figure 1: Locking points

The fixture may be installed in any orientation, on the ceiling or on a wall surface.

When installed horizontally with a downward beam-angle, water or dirt can potentially pool in the fan wells. Under normal operation the moisture will evaporate.

In locations with high rainfall, consider locating the fixture under cover or an overhang, or modify the position and orientation of the fixture to minimize pooling.

All SGM fixtures have locking points in the base for installation and rigging. In both standard and POI fixtures, the distance between the points from center to center is always 106 mm. Standard versions include 1/4 turn fasteners to mount SGM omega brackets. POI versions come with M-10 captive nuts for M-10 screws.

Always use the supplied omega bracket to rig a standard fixture. Lock the bracket with the 1/4-turn fasteners.

PLEASE NOTE! 1/4-TURN FASTENERS ARE ONLY LOCKED WHEN TURNED FULLY CLOCKWISE. DEPENDING ON THE STRUCTURE, PLEASE USE APPROPRIATE AND SECURE METHODS FOR MOUNTING THE OMEGA BRACKETS.

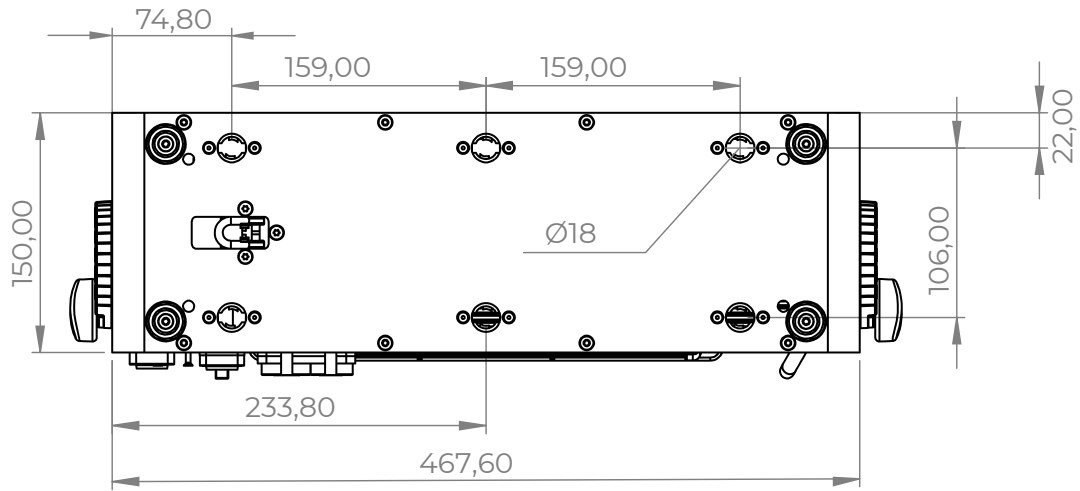

Figure 2: Dimensions for base locking points

RIGGING PROCESS USING SGM OMEGA BRACKETS



WARNING! ALWAYS USE MIN. 2 OMEGA BRACKETS WHEN RIGGING THE FIXTURE.

Step 1



Start the standard rigging process by blocking the lower working area, and make sure the work is performed from a stable platform.

1. Check that the clamp/bracket is undamaged. Supporting structure should be capable of bearing at least 10 times the weight of all installed fixtures, lamps, cables etc.
2. Bolt a clamp or bracket securely to the omega bracket with a M12 bolt (min. grade 8.8) and a lock nut. For longer term installations, choose outdoor rated hardware.
3. Align the omega bracket with the fixture base. For standard Omega Bracket, insert the fasteners into the fixture base bracket, and turn both levers a full 1/4 turn clockwise to lock.
4. Working from a stable platform, hang the fixture on a truss or other structure. Tighten the clamp/bracket. Verify that there are no combustible materials, cables, or surfaces to be illuminated within 0.3 m (12 in.) of the fixture.

Step 2



Step 3



5. Install a safety wire that can bear at least 10 times the weight of the fixture. The safety wire attachment point is designed to fit a carabiner AISI316 grade.
6. Verify that there are no combustible materials, cables, or surfaces to be illuminated within 0.3 m (12 in) of the fixture.
7. Check that there is no risk of the head/yoke colliding with other fixtures or structures.



WARNING! ALWAYS SECURE AN ELEVATED FIXTURE WITH A SAFETY WIRE. ALWAYS USE A SAFETY WIRE OF A GRADE AISI 316 STEEL. MAKE SURE THE SLACK OF THE SAFETY WIRE IS AT A MINIMUM. NEVER USE THE YOKE/HANDLE FOR SECONDARY ATTACHMENT.



Figure 3: Safety wire attachment point

Fasten a safety wire (not shown) between the load-bearing support structure and the safety wire attachment point on the device.

- The safety cable (not included in the package) must:
- Bear at least 10 times the weight of the device (SWL).
- Have a minimum gauge of 4 mm.
- Have a maximum length (free fall) = 30 cm (12 in.).

TILT LOCK

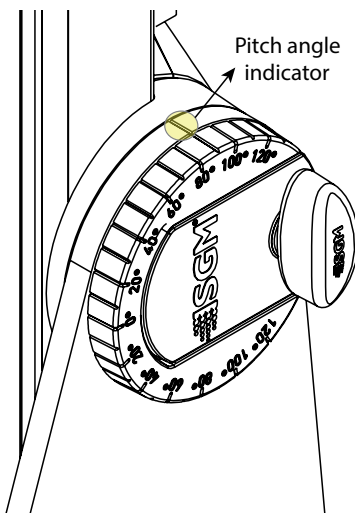

Figure 4: Standard tilt lock

The fixture head can pivot through $\pm 120^\circ$.

To adjust the tilt angle in standard versions:

- Loosen the two tilt wing-screws (one on each side) by turning them counter-clockwise.
- Tilt the fixture to the angle desired and hold it.
- Lock the position by re-tightening both tilt lock screws clockwise.

CAUTION!

ALWAYS LEAVE A FIXTURE TO COOL OFF FOR 15 MINUTES AFTER OPERATION BEFORE HANDLING.

POWER REQUIREMENTS

The fixture can operate on any 100–277 V, 50/60 Hz AC mains power supply, and draws a maximum of 630 W. Power is connected via the “Powercon” type connectors. Power plug is as per local code.

CONNECTING POWER



Wire	Color	Symbol	Conductor
	Black	L	live
	White	N	neutral (L2)
	green/yellow	\perp or \oplus	ground (earth)

Figure 5: Connecting AC Power

The power cable color coding is given in figure 5:

- Connect the black wire to live
- Connect the white wire to neutral (or phase 2 on 208V supplies)
- Connect the green/yellow wire to ground (earth)

For a temporary outdoor installation the mains cable must be fitted with a grounded connector intended for exterior use.

After connecting the fixture to power, run the on-board test by selecting the option “TEST→ LED PANEL TEST” in the menu, to ensure that the fixture and each LED are functioning correctly. (POI versions are tested through RDM.)

PLEASE NOTE! THE PROTECTIVE CAPS MUST BE SECURELY MOUNTED ON ANY UNUSED CONNECTORS, IN ORDER TO MAINTAIN INGRESS PROTECTION (IP RATING).

CAUTION!

DO NOT CONNECT THE FIXTURE TO AN ELECTRICAL DIMMER SYSTEM, AS DOING SO MAY CAUSE DAMAGE

CONNECTING DATA

The fixture is controllable using a DMX control device, and it can be connected using either a DMX cable, or via the fixture's built-in CRMX wireless receiver system.

When using a cabled DMX system, connect the DMX-In cable to the input connector and DMX-Out cable to the output, both on the rear of the fixture's base (chassis mounted male and female 5-pin XLR plugs). For outdoor installations, use only IP-rated XLR connectors suitable for outdoor use. Terminate the DMX out cable of the last fixture in the data link with a 120 ohm DMX termination.

Note that SGM fixtures provide a passive DMX Thru signal as DMX Out, instead of an active output signal.

CONNECTING A WIRELESS TRANSMITTER

The fixture is designed to look for wireless transmitters in 'connect' state when this option is not yet enabled. The fixture comes tested for wireless functionality from the factory, therefore the beginning of the pairing process is disconnect from the factory wireless DMX transceiver.

To connect the fixture to a wireless transmitter:

1. Log off the currently paired wireless transmitter. Go to SETTINGS → WIRELESS DMX → LOG OFF in the menu. Fixture confirms logged off.
2. Press the connect button on the wireless transmitter.
3. Confirm that the fixture has paired with the wireless transmitter.

SIGNAL PRIORITY

The fixture can be paired to an active wireless transmitter while also being connected to a cabled DMX signal. By default, the fixture will prioritize cabled DMX over wireless DMX. Through the Settings menu in the display or RDM, this can be changed so that the fixture will prioritize the wireless DMX signal over cabled DMX.

The active input type is displayed next to the wireless signal strength indicator. The signal strength can be also checked via RDM data by using an external RDM device.

USER INTERFACE

The fixture can be set up by using the control panel and OLED multi-line display on fixture's head or through RDM. The OLED display shows the current status and menu of the fixture. It is used to configure individual fixture settings and read error messages. The complete list of the menu and all commands available are listed in "[Control menu](#)".

Before turning on the fixture, make sure the power cable is properly connected. When the fixture is powered on it will boot and reset before displaying the selected operating mode and DMX start address. Navigate through the menus and options using the arrow buttons, and select items using the ENTER button.

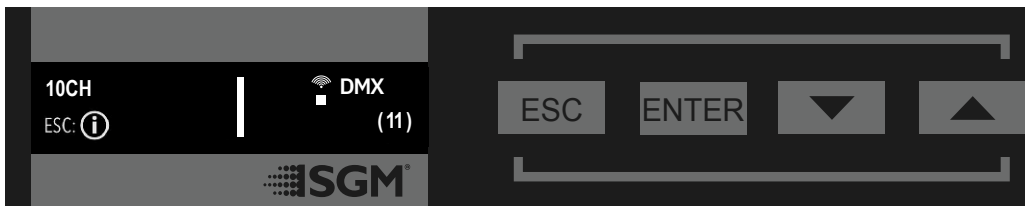

Figure 6: OLED display and control panel

USING THE DISPLAY PANEL

- Press the 'ENTER' button to access the menu or make a selection.
- Press the arrow buttons to scroll up and down in the menus.
- Press the 'ESC' button to take a step back in the menu.

SHORTCUTS

- ESC + ENTER: Press ENTER to confirm factory defaults.
- ESC + UP: Press ENTER to start LED test.
- UP + DOWN arrows simultaneously = flip the display upside-down.
- ENTER + DOWN (hold down for 10 sec): Keypad unlock

DISPLAY

OPERATIONAL MODE (A)

Displays the current mode (quick color, stand-alone, or DMX mode). The fixture is set by default to be controlled in DMX mode.

DMX ADDRESS (B)

Displays the current DMX address. The DMX address is altered directly from this view.

EXTERNAL DATA PROTOCOL (C)

Shows the external data protocol.

- When 'DMX' is displayed: the fixture responds to data received through cabled DMX.
- When 'CRMX' is displayed: the fixture responds to data received through wireless DMX.
- When 'CRMX-B' is displayed: the fixture responds to data received through wireless DMX and bridge data to wired DMX.

NEXT AVAILABLE ADDRESS (D)

The next available DMX address will show immediately, depending on the fixture's DMX footprint.

EXTERNAL DATA INDICATOR (E)

The DMX signal indicator will flash when the DMX/CRMX signal is received.

INFORMATION PANEL (F)

The information panel is accessed by pressing ESC. It functions as a way to quickly get an overview of errors, notifications and important settings. Errors will always be shown first, followed by a divider line. All other information such as custom PWM frequency will be shown below the divider line. The current page and the total amount of pages of information is shown in the top right corner of the display.

WARNING INDICATOR

If any errors are detected, the exclamation point will alternate with the current display for easy detection.

To read the error message, go to the information panel by pressing ESC.

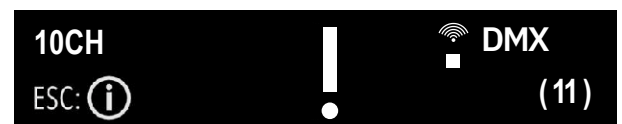
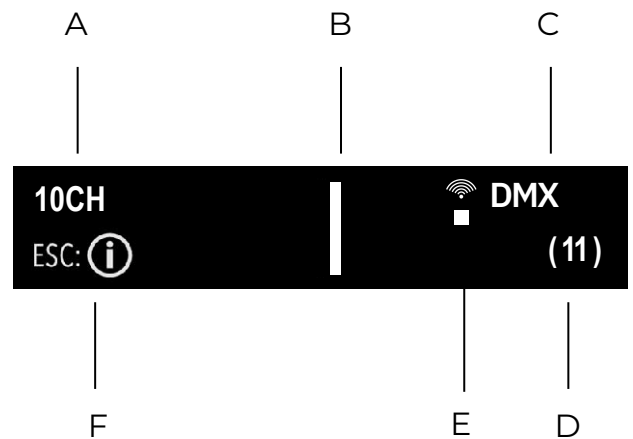

ABOUT DMX

The fixture can be controlled using signals sent by a DMX controller on a number of DMX channels.

DMX is the USITT DMX512-A standard, based on the RS-485 standard. The signal is sent as DMX data from a console (or a controller) to the fixtures via a shielded twisted pair cable designed for RS-485 devices.

The cables can be daisy chained between the fixtures, and up to 32 fixtures can be connected on the same DMX link. Up to 300 m. (~1000ft.) of cable is achievable with high quality DMX cables. All DMX links must be terminated by connecting a DMX termination plug to the last fixture's 5 pin DMX out connector.

PLEASE NOTE! STANDARD MICROPHONE CABLE IS NOT SUITABLE FOR TRANSMITTING DMX. UP TO 32 FIXTURES CAN BE LINKED TO THE SAME DMX CHAIN. ADDITIONAL FIXTURES WILL OVERLOAD THE LINK.

DMX START ADDRESS

The fixture can be operated in different DMX modes. For any of the modes, the first channel used to receive data from a DMX control device is known as the DMX start address.

For independent control, each fixture must be assigned its own DMX start address. For example, if the first RGBW fixture is set to 6ch CTC DMX mode with a start DMX address of 101, the following RGBW fixture in the DMX chain should then be set to a DMX address of 107. As the first fixture uses all the first 6 DMX channels, including channel 101, the next available channel is 107 ($101+6=107 \gg 107$).

If two or more fixtures have the same DMX start address, they will behave identically. Incorrect settings will result in unpredictable responses from the lighting controller. Address sharing can be useful for diagnostic purposes and symmetrical control.

SET/EDIT DMX ADDRESS

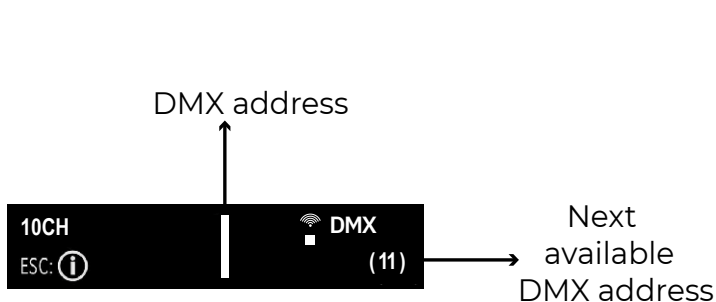

The DMX address is shown on the OLED display in the control panel. To change the address setting, press the up and down arrows. When the desired address is displayed, press ENTER to save the setting. For your convenience, the next available DMX address is displayed to the right. Note that channel spacing is determined by the number of channels of the DMX mode.

See "User Interface" on page 12 for instructions on using the display panel.

The fixture also offers the option to set the DMX address through RDM.

SETTING THE DMX MODE

When selecting ENTER → MODE → Select mode in the control panel, it is possible to choose the DMX mode that provides the required controls. Confirm the chosen mode by pressing 'Enter'.

DMX CHARTS

The fixture operates in different DMX modes. Each DMX mode has its own DMX chart. All DMX charts are available for download at www.sgmlight.com under the respective product, or upon request via support@sgmlight.com

SETTING A STATIC COLOR MANUALLY

The standard fixture can be configured to display a predefined and static color.

To set up a static color select ENTER → MANUAL → QUICK COLOR.

Note that, once the MANUAL → QUICK COLOR settings are changed, the fixture will be set, by default, to automatically start in quick color mode whenever it is powered on. This can be reset through the menu SETTINGS → STARTUP MODE → SELECT STARTUP MODE.

The current quick color program can always be stopped by going to:

ENTER → MANUAL → STOP PROGRAM

USING STANDALONE OPERATION

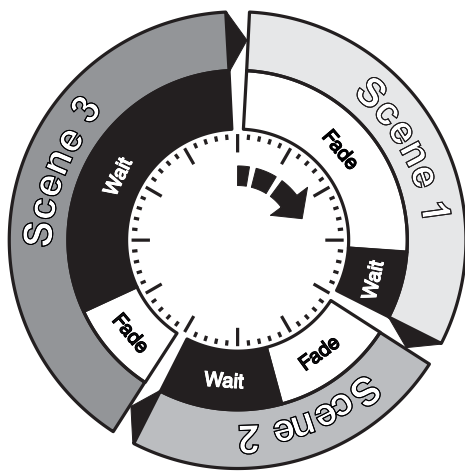

Figure 7: Standalone operation

To define a stand-alone program, press ENTER → MANUAL → PROGRAM EDITOR. The standalone mode of the fixture's startup is enabled by selecting:

ENTER → SETTINGS → STARTUP MODE → SELECT STARTUP MODE → PROGRAM 1-3.

The chosen program will run its length cyclically whenever the fixture is powered on.

To temporarily run an internal program, go to:

ENTER → MANUAL → RUN PROGRAM.

To stop an active internal program, go to:

ENTER → MANUAL → STOP PROGRAM.

Up to three stand-alone programs

can be defined and run from the menus, and one of the programs can be set to run by default whenever the fixture is powered on.

One program can have up to 24 scenes, playing continuously in a loop, with its own RGB and shutter settings. Each scene has a definable fade-in time for the transition from one color to the next, and a wait (static) time of up to 120 minutes and 59 seconds.

FACTORY DEFAULT

- Set DMX address to 1
- Set 6 Channel CTC DMX mode
- Set screensaver to Off
- Set flip screen to not-flipped
- Disable Startup Programs
- Set all Quick Color values to zero
- Disable DMX Loss
- Disable Fast Speed mode
- Set all values in Manual Programs to zero
- Set Fan mode to Auto
- Disabled Keypad Lock
- Set Wireless Priority to DMX
- Set Custom Frequency to Default
- Log off wireless

LED ENGINE

The P-6 Series is a fixture with 24 high-power RGBW LEDs, divided into 6 individually controllable segments, which generates wide-ranging color effects and pixel-mapping combinations for creative lighting designs.

Color temperature correction

The P-6 Series offers seamless CTC (color temperature correction) control from 2000° Kelvin - 10000° Kelvin.

Ultra high-speed strobe effect

The ultra high-speed strobe effect generates random strobe and pulse effects with variable speed.

Beam angle

The standard P-6 offers a native 10° beam angle that can be modified using different optional magnetic holographic filter frames and barndoors; the P-6 POI offers 10°, 25° and 35° native beam angle.

INDIVIDUAL FIXTURE SETTINGS

Setting the dimming curve

Setting the dimming curve will determine the fixture's behaviour, when changing the light intensity between 0% - 100%.

Linear control provides uniform adjustment throughout the control action, whereas gamma corrected dimming provides finer control at low light levels, where the eye is more sensitive to change. By default, the P-6 uses gamma corrected dimming. For a uniform response, set all fixtures to the same dimming curve.

Setting the fan mode

For operating environments where low-noise is a requirement, or where the fixture will be operating at high temperatures, it is possible to adjust the default fan speed by going to:

SETTINGS → FAN MODE in the menu.

Mode.

- Select operation mode "Legacy" to comply with firm-ware versions less than 4.00

- Select operation mode "Standard" to comply with new firmware versions that results in a new set of DMX modes.

Flipping the OLED display (POI n.a.)

If the fixture is installed hanging upside down, it might be useful to flip the display so that it is easier to read.

To flip the display, press:

ENTER and select SETTINGS → FLIP DISPLAY, or press the up and down buttons on the control panel at the same time.

Setting the OLED display saver (POI n.a.)

By default, the OLED display is off after a short period when the control panel is not in use. The display can also be set to be dimmed, enabling user always to read the display. Pressing any key will always turn on the display or restore it to normal brightness.

To configure the display settings, press:
ENTER → SETTINGS → DISPLAY SAVER.

Setting the Fast Speed mode

This enables LED fast speed drive and reduce pitch noise

PLEASE NOTE! TO AVOID THE RISK OF DISPLAY DETERIORATION CAUSED BY LONG TERM USE, IT IS RECOMMENDED TO SELECT THE SETTING → DISPLAY OFF.

CONTROL MENU

LEVEL 1	LEVEL 2	LEVEL 3	FUNCTION	
Mode	Select Mode	-	Select DMX mode.	
	Select Operation Mode	-	Initiate a self-test sequence.	
Test	Display Test	-	Service use only.	
	Off	-	Stop test sequence execution.	
Manual	Quick Color Editor	Red	Static quick color - red mix (0-255). Sets fixture to quick color startup mode.	
		Green	Static quick color - green mix (0-255). Sets fixture to quick color startup mode.	
		Blue	Static quick color - blue mix (0-255). Sets fixture to quick color startup mode.	
		White	Static quick color - white mix (0-255). Sets fixture to quick color startup mode.	
		Full color calibrate	Enable or disable color calibration.	
	Stop		Stop current running internal sequence or Quick Color.	
	Program Run	1, 2 or 3	Run internal sequence 1, 2 or 3.	
	Macro Run		Runs the pre-programmed macro.	
	Quick Color Run		Runs the pre-programmed Quick Color.	
	Program Editor	Program 1, 2, or 3		Currently selected program (1, 2 or 3).
		Scene		Currently selected scene (1-24).
		Red		Red value in currently selected scene (0-255).
		Green		Green value in currently selected scene (0-255).
		Blue		Blue value in currently selected scene (0-255).
		Fade Time Min		Fade-in (transition) time to current scene in min. (0-511).
		Fade Time Sec		Fade-in (transition) time to current scene in sec. (0-59).
		Wait Time Min		Wait (static) time in current scene in min. (0-998).
	Wait Time Sec		Wait (static) time in current scene in sec. (0-59).	
	Macro Color Editor	Macro Color		Select macro color.
		Macro Intensity		Intensity level of the macro.
Settings	Wireless DMX	Wireless Connection and Log-Off	Enable or disable wireless connection.	
		Wireless Priority Enable / Disable	Enable or disable wireless priority	
		Bridge DMX Enable / Disable	Enable or disable wireless to wired DMX bridging.	
	Service Menu			
	Service Pin		PIN for service by service centers.	
	Factory Default		Reset the fixture to factory default settings.	
	Power Limiter	Full Power		
		100W		
	Fast Speed	Enable or disable fast PWM		
	Fan Mode	Auto		
		Low Noise	Low fan speed for quiet operation.	
	Display Saver	Display Off		
		Display Dim		
	LED PWM Frequency	Selectable PWM from 3.29 to 21kHz		
	DMX Loss Function	DMX Hold		
		Quick Color		
		Blackout		
All On				
DMX Hold 5 min				

LEVEL 1	LEVEL 2	LEVEL 3	FUNCTION	
	Startup mode	DMX		
		Quick Color		
		Macro		
		Program 1		
		Program 2		
		Program 3		
System	Product Type		Display product type.	
	Firmware Version		Display installed firmware version.	
	Hardware Revision		Display hardware revision.	
	Serial Number		Display serial number.	
	RDM ID		Display RDM ID. (Unique RDM ID for identification).	
	DMX View		Display received DMX levels.	
	Sensors	MAIN TEMP		Displays fixture temperatures.
		LED L1 TEMP		
		LED L2 TEMP		
		LED L3 TEMP		
		LED R1 TEMP		
		LED R2 TEMP		
		LED R3 TEMP		
		HUMIDITY HEAD		
		WIRELESS SIGNAL		
		WIRELESS PAIRED		
LIGHT PWM				
VOLTAGE 24V				
FIXTURE DERATING				
Power On Time		Displays total power on time.		
LED On Time		Displays individual LED on time.		

SUPPORTED RDM FUNCTIONS

The P-6 Series features support for various RDM functions.

RDM (Remote Device Management) is a protocol enhancement to USITT DMX512 that allows bi-directional communication between the fixtures and the controller over a standard DMX line. This protocol will allow configuration, status monitoring, and management. A RDM controller is needed to get control over the supported parameters. See the tables below for supported RDM

functions.

PLEASE NOTE! THE RDM CONTROLLER COMMUNICATES WITH THE FIXTURES TO SHOW ONLY THE AVAILABLE OPTIONS FOR EACH RDM FUNCTION. TABLES ARE SUBJECT TO CHANGE WITHOUT NOTICE.

SENSORS

RDM enables various sensor readouts for remote device monitoring. See the table below for sensors and sensor types.

PLEASE NOTE! THE RDM CONTROLLER COMMUNICATES WITH THE FIXTURES TO SHOW ONLY THE AVAILABLE SENSORS FOR THIS FIXTURE. THE TABLE IS SUBJECT TO CHANGE WITHOUT NOTICE.

NAME	SENSOR TYPE
Humidity Head	Other
Wireless Signal Strength	Other
Wireless Paired	Other
Light PWM	Other
Voltage	Voltage
Fixture Derating	Other

NAME	SENSOR TYPE
Mainboard	Temperature
LED Left 1	Temperature
LED Left 2	Temperature
LED Left 3	Temperature
LED Right 1	Temperature
LED Right 2	Temperature

PID COMMANDS

PID	ACTIONS ALLOWED	NAME
0x0082	GET/SET	Device Label
0x0081	GET	Manufacturer Label
0x00E0	GET/SET	DMX Personality
0x00E1	GET	DMX Personality description
0x0200	GET	Sensor Definition
0x0201	GET/SET	Sensor Value
0x0080	GET	Device Model Description
0x0400	GET/SET	Device Hours
0x0401	GET/SET	Lamp Hours
0x0051	GET	Parameter Description
0x0501	GET/SET	Display Level
0x0500	GET/SET	Display Invert
0x0090	GET/SET	Factory Defaults
0x1001	SET	Reset Device
0x0120	GET	Slot Info
0x0121	GET	Slot Description
0x0122	GET	Default Slot Value
0x0030	GET	Status Messages
0x0031	GET	Status Id Description

PID	ACTIONS ALLOWED	NAME
0x8626	SET	CRM Log Off
0x8060	GET	Serial Nr.
0x8625	GET/SET	FAN 0=AUTO 1=LOW NOISE 2=OFF
0x8634	GET/SET	LOSS 0=HO 1=WHI 2=OF 3=QC 4=HO5
0x8635	GET/SET	START 0=DMX 1=QC 2=MAC 3-5=PRG
0x8636	GET	Active Error
0x8637	GET/SET	BRIDGE 1=ENABLE 2=DIS-ABLE
0x8639	GET/SET	POI-LED 1=ENABLE 2=DIS-ABLE
0x863A	GET/SET	100W-LIMIT 1=ENABLE 2=DISABLE
0x8638	GET/SET	KEYPAD LOCK EN=1 DIS=2
0x863B	GET / SET	PRIOR-WIREL 1=ENABLE 2=DISABLE
0x863D	GET / SET	OPERATION-MODE LEG=0 STD=1
0x863C	GET / SET	FAST SPEED 0=DISABLE 1=ENABLE

BARNDOORS



Figure 8 : 4-way barndoor for P-6



Figure 9 : 8-way barndoor for P-6

The P-6 features 4-way and 8-way barndoors. The barndoors are designed and intended to be mounted on the fixture without the use of any tools.

To install the barndoors:

1. Attach the lower plug-in pins to the bottom part of the P-6 front.
2. Pull the two upper lock pins and fit the upper part of the barndoor in the P-6 head.
3. Release the lock pins and check that they are correctly in place.

PLEASE NOTE! THE ANTI-GLARE SHIELDS ARE SUITABLE FOR BOTH PERMANENT OUTDOOR AND INDOOR INSTALLATIONS.

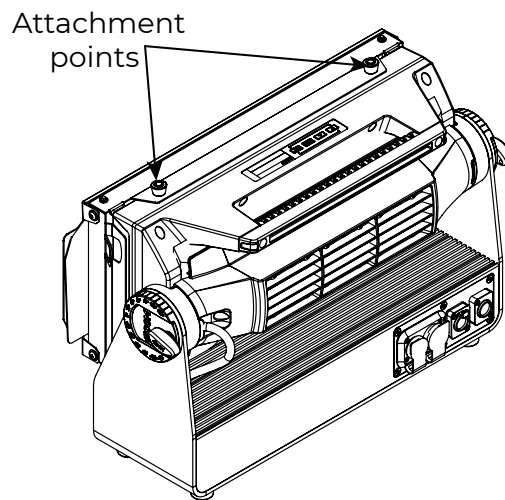
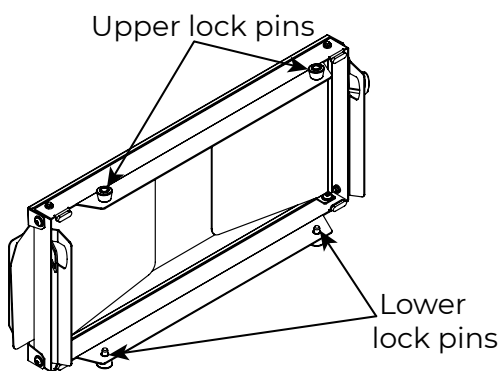

Figure 10.: Barndoor attachment

FILTER FRAMES



Figure 11 : Filter frame for P-6

The P-6 features various optional, magnetic holographic filter frames:

- Medium angle (19°).
- Wide angle (45°).
- Elliptical wide angle horizontal (63°x12°).
- Elliptical wide angle vertical (12°x63°).
- Empty filter frame for custom filters.

The filter frames are easily mounted due to their magnetic properties. To install them, it's only required to position the filter frame in front of the light, and it quickly snaps into place.

The frames are fitted with a safety wire to secure the frame to the handle of the P-6.

A filter frame can be mounted simultaneously with a barndoor.

MAINTENANCE

Updated maintenance procedures and frequency are available at www.sgmlight.com under the respective product.



Figure 12: SGM Vacuum Test Kit

SGM VACUUM TEST KIT

The Vacuum Test Kit is an accessory suitable for all SGM IP-rated fixtures, made for testing the IP integrity upon reassembly.

In order to ensure the IP-rating of the fixture, it's highly recommended that the fixture is always vacuum tested after installing or swapping any part that might compromise the IP-rating, e.g., swapping the front lens.

SGM disclaims liability for any damage occasioned by the non-use, or inability to use, the vacuum test kit after reassembling the fixture.



Figure 13: SGM Uploader Cable

USB - XLR UPLOADER CABLE

The SGM USB to DMX cable is an accessory used mainly to update the fixture with the latest SGM firmware. See below how to update the fixture with the latest firmware.

The SGM Uploader cable is also used for controlling the DMX values channel by channel through the Firmware Uploader Tool software (available for download at www.sgmlight.com).

FIRMWARE UPDATES

Updated maintenance procedures and frequency are available at www.sgmlight.com under the respective product.

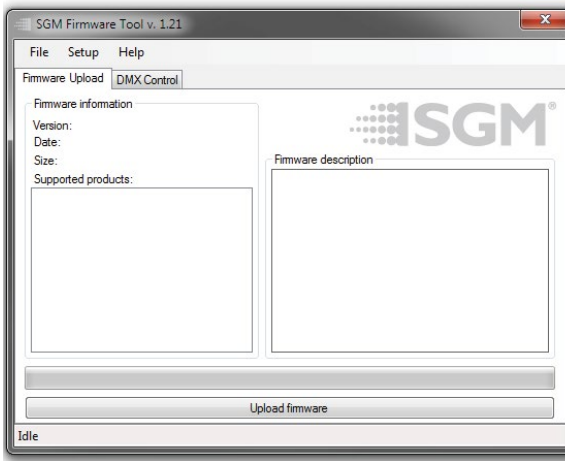

Figure 14: SGM Firmware tool

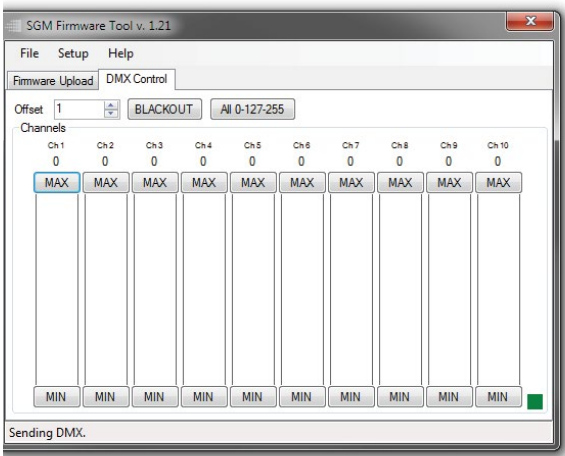

Figure 15: SGM Firmware tool

Fixture firmware can be identified by:

- When powering the fixture, the display shows the current installed firmware version during start-up.
- Go to MENU → SYSTEM → FIRMWARE VERSION
- Through RDM

To update a fixture with the latest firmware, use an SGM USB 5-Pin-XLR uploader cable, and a Windows-based computer with the SGM Firmware Tool software installed (available for download at www.sgmlight.com).

- Download the SGM Firmware Tool software from the SGM website
- Download latest firmware file from product web page on the SGM website
- Connect either Std or POI uploader cable depending on which is more suitable for the installation
- Launch SGM Firmware Tool on a windows PC
- Click “File” then “Open” and navigate to the firmware file needed, select it and click “Open”
- The firmware is now loaded in the uploader, click “Upload Firmware”

The fixture will now update and reboot

The Firmware Tool software offers a simple DMX controller featuring 512 DMX channels for test purposes.

IT IS RECOMMENDED KEEP FIRMWARE UPDATED. THE LATEST FIRMWARE VERSION IS ALWAYS AVAILABLE FOR DOWNLOAD UNDER THE RESPECTIVE PRODUCT AT WWW.SGMLIGHT.COM.

CLEANING

SGM fixtures with IP65 or IP66-rating do not need any cleaning procedures inside the fixture. However, cleaning the front lens may be needed to achieve the maximum light output after exposure to dust, sand, or dirt. The exterior housing can also be cleaned to get a better look. To maintain adequate cooling, fans must be cleaned periodically.

Whenever necessary, clean the fixture using a soft cloth dampened with a solution of water and a mild detergent. Do not use products that contain solvents, abrasives, or caustic agents for cleaning, as they can cause damage to hardware, cables, and connectors.

The level of cleaning required will vary greatly depending on the operating environment and installation. Therefore, it is recommended to do frequent check-ups the first few weeks of operation to see how often cleaning is necessary.

TROUBLESHOOTING

PROBLEM	POTENTIAL CAUSE(S)	REMEDIES
Fixture does not respond or appears to be completely dead.	No power to the fixture.	Confirm that the power is switched on, confirm that the cables are plugged in.
	Main fuse is blown.	Contact SGM support or certified SGM service partner.
Fixture suddenly turned off.	Power was turned off.	Check the power supply, switches and breakers.
Fixture suddenly stopped responding.	Wireless transmitter or connections was disconnected/ tampered with.	Inspect the wireless transmitter and connections.
	DMX cables were disconnected.	Inspect DMX cables.
Fixture operates irregularly/ abnormally.	DMX cable polarization is inverted (pin 2 + 3).	Install a phase-inverter or replace cables.
	DMX link is not terminated.	Install a XLR 120 ohm DMX termination at the end of the DMX link.
	Corrupted DMX cable.	Replace or repair defective cables and/ or connectors.
	The fixture operates an internal program.	Go to MENU → MANUAL → STOP PROGRAM.
	A corrupted fixture generates noise/ disruptions on the DMX link.	Track and isolate the corrupted fixture.
Color is uneven.	The minimum values are out of calibration.	Contact your local SGM dealer or support@sgmlight.
	The SGM Calibration Data set has been lost.	Contact your local SGM dealer or support@sgmlight.

FIXTURES AND ACCESSORIES

PLEASE NOTE! THE LIST BELOW IS SUBJECT TO CHANGE WITHOUT NOTICE.

ORDERING INFORMATION

The ordering information of the product and it's variants can be found on the product page www.sgmlight.com

ACCESSORIES

The ordering information of the product and it's variants can be found on the product page www.sgmlight.com

SUPPORT HOTLINE

SGM offers 24/7 technical support.

Worldwide: +45 3840 3840

US: +1 407-242-6217

support@sgmlight.com

APPROVALS AND CERTIFICATIONS

Conforms to 2014/35/EU: Low Voltage Directive
Conforms to 2014/30/EU: EMC Directive
Conforms to 2011/65/EU: RoHS2 Directive
Conforms to UK SI 2016 No. 1101: The Electric Equipment (Safety) Regulations 2016
Conforms to UK SI 2016 No. 1091: Electromagnetic Compatibility Regulations 2016
Conforms toUK SI 2012 No. 3032: Restriction of the Use of Certain Hazardous Substances
in Electrical and Electronic Equipment Regulations 2012 (RoHS2)
Conforms toANSI/UL Std. 1573
Certified to..... CSA Std. C22.2 No. 166



The information in this document is subject to change without notice.
For the latest information, visit www.sgmlight.com.



SGM LIGHTING APS

Sommervej 23

8210 Aarhus V

Denmark

Tel: +45 70 20 74 00

info@sgmlight.com

www.sgmlight.com